

# OPERATION AND PARTS MANUAL



**MQ POWER**

## **MODEL DCA25USI4CAN 60HZ WHISPERWATT™ GENERATOR (ISUZU BV-4LE2-NYGD02 DIESEL ENGINE)**

**PARTS LIST NO. M1874400004**

Revision #2 (11/23/16)



To find the latest revision of this  
publication, visit our website at:  
[www.multiquip.com](http://www.multiquip.com)



**THIS MANUAL MUST ACCOMPANY THE EQUIPMENT AT ALL TIMES.**

## FUEL AND CHEMICAL EXPOSURE WARNINGS

---

 <b>WARNING</b> 
Diesel engine exhaust and some of its constituents are known to cause cancer, birth defects and other reproductive harm.

## REPORTING SAFETY DEFECTS

---

If you believe that your vehicle has a defect that could cause a crash or could cause injury or death, you should immediately inform the National Highway Traffic Safety Administration (NHTSA) in addition to notifying Multiquip Inc. at 1-800-421-1244.

If NHTSA receives similar complaints, it may open an investigation, and if it finds that a safety defect exists in a group of vehicles, it may order a recall and remedy campaign. However, NHTSA cannot become involved in individual problems between you, your dealer, or Multiquip Inc.

To contact NHTSA, you may either call the Vehicle Safety Hotline toll-free at 1-888-327-4236 (TTY: 1-800-424-9153), go to <http://www.safercar.gov>, or write to:

Administrator  
NHTSA  
1200 New Jersey Avenue, SE  
Washington, DC 20590

You can also obtain information about motor vehicle safety from <http://www.safercar.gov>.

# TABLE OF CONTENTS

## DCA25USI4CAN 60 Hz

### Generator

Fuel And Chemical Exposure Warnings .....	2
Reporting Safety Defects .....	3
Table Of Contents .....	4
Parts Ordering Procedures .....	5
Safety Information .....	6-11
Specifications .....	12
Dimensions .....	13
Installation .....	14-15
General Information .....	16
Major Components .....	17
Generator Control Panel .....	18
Engine Operating Panel .....	19
Output Terminal Panel Familiarization .....	20-22
Load Application .....	23
Generator Outputs .....	24
Generator Outputs/Gauge Reading .....	25
Output Terminal Panel Connections .....	26-27
600 VAC Auto Transformer Connections .....	28
Inspection/Setup .....	22-32
Generator Start-Up Procedure .....	33-34
Generator Shut-Down Procedures .....	35
Maintenance .....	36-38
Trailer Maintenance .....	39-43
Trailer Wiring Diagram .....	44
Generator Wiring Diagram .....	45
600 VAC Auto Transformer Wiring Diagram .....	46
Engine Wiring Diagram .....	48-49
Troubleshooting (Generator) .....	50
Explanation Of Code In Remarks Column .....	52
Suggested Spare Parts .....	53

### COMPONENT DRAWINGS

Generator Assembly .....	54-55
Control Box Assembly .....	56-59
Engine And Radiator Assembly .....	60-63
Output Terminal Assembly .....	64-65
Battery Assembly .....	66-67
Muffler Assembly .....	68-69
Fuel Tank Assembly .....	70-71
Enclosure Assembly .....	72-77
Rubber Seals Assembly .....	78-79
Nameplate and Decals Assembly .....	80-83
3Ø 600 VAC Transformer Assembly .....	84-85
Terms And Conditions Of Sale — Parts .....	86

# PARTS ORDERING PROCEDURES

## Ordering parts has never been easier! Choose from three easy options:

Effective:  
January 1<sup>st</sup>, 2006

www.multiquip.com



### Order via Internet (Dealers Only):

Order parts on-line using Multiquip's SmartEquip website!

- View Parts Diagrams
- Order Parts
- Print Specification Information



If you have an MQ Account, to obtain a Username and Password, E-mail us at: [parts@multiquip.com](mailto:parts@multiquip.com).

To obtain an MQ Account, contact your District Sales Manager for more information.

Goto [www.multiquip.com](http://www.multiquip.com) and click on

**Order Parts** to log in and save!

Use the **internet** and qualify for a **5% Discount** on *Standard orders* for all orders which include complete part numbers.\*

Note: Discounts Are Subject To Change



### Order via Fax (Dealers Only):

All customers are welcome to order parts via Fax.

**Domestic (US) Customers dial:**  
1-800-6-PARTS-7 (800-672-7877)

**Fax** your order in and qualify for a **2% Discount** on *Standard orders* for all orders which include complete part numbers.\*

Note: Discounts Are Subject To Change



**Order via Phone: Domestic (US) Dealers Call:**  
1-800-427-1244

### Non-Dealer Customers:

Contact your local Multiquip Dealer for parts or call 800-427-1244 for help in locating a dealer near you.



**International Customers** should contact their local Multiquip Representatives for Parts Ordering information.

## When ordering parts, please supply:

- |   |  |
|---|--|
| <input type="checkbox"/> Dealer Account Number                                | <input type="checkbox"/> Specify Preferred Method of Shipment:                         |
| <input type="checkbox"/> Dealer Name and Address                              | <input checked="" type="checkbox"/> UPS/Fed Ex <input checked="" type="checkbox"/> DHL |
| <input type="checkbox"/> Shipping Address (if different than billing address) | <input type="checkbox"/> Priority One <input checked="" type="checkbox"/> Truck        |
| <input type="checkbox"/> Return Fax Number                                    | <input type="checkbox"/> Ground  |
| <input type="checkbox"/> Applicable Model Number                              | <input type="checkbox"/> Next Day  |
| <input type="checkbox"/> Quantity, Part Number and Description of Each Part   | <input type="checkbox"/> Second/Third Day  |

### NOTICE

All orders are treated as *Standard Orders* and will ship the same day if received prior to 3PM PST.

WE ACCEPT ALL MAJOR CREDIT CARDS!



# SAFETY INFORMATION

Do not operate or service the equipment before reading the entire manual. Safety precautions should be followed at all times when operating this equipment. Failure to read and understand the safety messages and operating instructions could result in injury to yourself and others.

## SAFETY MESSAGES

The four safety messages shown below will inform you about potential hazards that could injure you or others. The safety messages specifically address the level of exposure to the operator and are preceded by one of four words: **DANGER**, **WARNING**, **CAUTION** or **NOTICE**.

## SAFETY SYMBOLS

 **DANGER**

Indicates a hazardous situation which, if not avoided, **WILL** result in **DEATH** or **SERIOUS INJURY**.

 **WARNING**

Indicates a hazardous situation which, if not avoided, **COULD** result in **DEATH** or **SERIOUS INJURY**.







 **CAUTION**

Indicates a hazardous situation which, if not avoided, **COULD** result in **MINOR** or **MODERATE INJURY**.

**NOTICE**

Addresses practices not related to personal injury.

Potential hazards associated with the operation of this equipment will be referenced with hazard symbols which may appear throughout this manual in conjunction with safety messages.

Symbol	Safety Hazard
	Lethal exhaust gas hazards
	Explosive fuel hazards
	Burn hazards
	Overspeed hazards
	Rotating parts hazards
	Pressurized fluid hazards
	Electric shock hazards

# SAFETY INFORMATION

## GENERAL SAFETY

### CAUTION

- **NEVER** operate this equipment without proper protective clothing, shatterproof glasses, respiratory protection, hearing protection, steel-toed boots and other protective devices required by the job or city and state regulations.



- **NEVER** operate this equipment when not feeling well due to fatigue, illness or when under medication. 
- **NEVER** operate this equipment under the influence of drugs or alcohol.



- **ALWAYS** check the equipment for loosened threads or bolts before starting.
- **DO NOT** use the equipment for any purpose other than its intended purposes or applications.

### NOTICE

- This equipment should only be operated by trained and qualified personnel 18 years of age and older.
- Whenever necessary, replace nameplate, operation and safety decals when they become difficult read.
- Manufacturer does not assume responsibility for any accident due to equipment modifications. Unauthorized equipment modification will void all warranties.

- **NEVER** use accessories or attachments that are not recommended by MQ Power for this equipment. Damage to the equipment and/or injury to user may result.

- **ALWAYS** know the location of the nearest **fire extinguisher**.



- **ALWAYS** know the location of the nearest **first aid kit**.



- **ALWAYS** know the location of the nearest phone or **keep a phone on the job site**. Also, know the phone numbers of the nearest **ambulance, doctor and fire department**. This information will be invaluable in the case of an emergency.

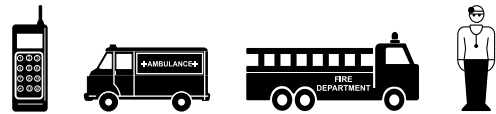

## GENERATOR SAFETY

### DANGER

- **NEVER** operate the equipment in an explosive atmosphere or near combustible materials. An explosion or fire could result causing severe **bodily harm or even death**.



### WARNING

- **NEVER** disconnect any **emergency or safety devices**. These devices are intended for operator safety. Disconnection of these devices can cause severe injury, bodily harm or even death. Disconnection of any of these devices will void all warranties.

### CAUTION

- **NEVER** lubricate components or attempt service on a running machine.

### NOTICE

- **ALWAYS** ensure generator is on level ground before use.
- **ALWAYS** keep the machine in proper running condition.
- Fix damage to machine and replace any broken parts immediately.
- **ALWAYS** store equipment properly when it is not being used. Equipment should be stored in a clean, dry location out of the reach of children and unauthorized personnel

# SAFETY INFORMATION

## ENGINE SAFETY

### DANGER

- The engine fuel exhaust gases contain poisonous carbon monoxide. This gas is colorless and odorless, and can cause death if inhaled.
- The engine of this equipment requires an adequate free flow of cooling air. **NEVER** operate this equipment in any enclosed or narrow area where free flow of the air is restricted. If the air flow is restricted it will cause injury to people and property and serious damage to the equipment or engine.

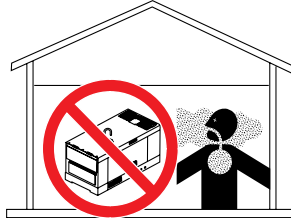

### WARNING

- **DO NOT** place hands or fingers inside engine compartment when engine is running.
- **NEVER** operate the engine with heat shields or guards removed.
- Keep fingers, hands hair and clothing away from all moving parts to prevent injury.
- **DO NOT** remove the radiator cap while the engine is hot. High pressure boiling water will gush out of the radiator and severely scald any persons in the general area of the generator.
- **DO NOT** remove the coolant drain plug while the engine is hot. Hot coolant will gush out of the coolant tank and severely scald any persons in the general area of the generator.



### CAUTION

- **NEVER** touch the hot exhaust manifold, muffler or cylinder. Allow these parts to cool before servicing equipment.



## NOTICE

- **NEVER** run engine without an air filter or with a dirty air filter. Severe engine damage may occur. Service air filter frequently to prevent engine malfunction.
- **NEVER** tamper with the factory settings of the engine or engine governor. Damage to the engine or equipment can result if operating in speed ranges above the maximum allowable.
- Wet stacking is a common problem with diesel engines which are operated for extended periods with light or no load applied. When a diesel engine operates without sufficient load (less than 40% of the rated output), it will not operate at its optimum temperature. This will allow unburned fuel to accumulate in the exhaust system, which can foul the fuel injectors, engine valves and exhaust system, including turbochargers, and reduce the operating performance.



In order for a diesel engine to operate at peak efficiency, it must be able to provide fuel and air in the proper ratio and at a high enough engine temperature for the engine to completely burn all of the fuel.

Wet stacking does not usually cause any permanent damage and can be alleviated if additional load is applied to relieve the condition. It can reduce the system performance and increase maintenance. Applying an increasing load over a period of time until the excess fuel is burned off and the system capacity is reached usually can repair the condition. This can take several hours to burn off the accumulated unburned fuel.

- State Health Safety Codes and Public Resources Codes specify that in certain locations, spark arresters must be used on internal combustion engines that use hydrocarbon fuels. A spark arrester is a device designed to prevent accidental discharge of sparks or flames from the engine exhaust. Spark arresters are qualified and rated by the United States Forest Service for this purpose. In order to comply with local laws regarding spark arresters, consult the engine distributor or the local Health and Safety Administrator.



# SAFETY INFORMATION

## FUEL SAFETY

### DANGER

- **DO NOT** start the engine near spilled fuel or combustible fluids. Diesel fuel is extremely flammable and its vapors can cause an explosion if ignited.
- **ALWAYS** refuel in a well-ventilated area, away from sparks and open flames.
- **ALWAYS** use extreme caution when working with **flammable** liquids.
- **DO NOT** fill the fuel tank while the engine is running or hot.
- **DO NOT** overfill tank, since spilled fuel could ignite if it comes into contact with hot engine parts or sparks from the ignition system.
- Store fuel in appropriate containers, in well-ventilated areas and away from sparks and flames.
- **NEVER** use fuel as a cleaning agent.
- **DO NOT** smoke around or near the equipment. Fire or explosion could result from fuel vapors or if fuel is spilled on a hot engine.



## TOWING SAFETY

### CAUTION

- Check with your local county or state safety towing regulations, in addition to meeting **Department of Transportation (DOT) Safety Towing Regulations**, before towing your generator.
- Refer to MQ Power trailer manual for additional safety information.
- In order to reduce the possibility of an accident while transporting the generator on public roads, **ALWAYS** make sure the trailer that supports the generator and the towing vehicle are mechanically sound and in good operating condition.
- **ALWAYS** shutdown engine before transporting



- Make sure the hitch and coupling of the towing vehicle are rated equal to, or greater than the trailer “gross vehicle weight rating.”
- **ALWAYS** inspect the hitch and coupling for wear. **NEVER** tow a trailer with defective hitches, couplings, chains, etc.
- Check the tire air pressure on both towing vehicle and trailer. **Trailer tires should be inflated to 50 psi cold.** Also check the tire tread wear on both vehicles.
- **ALWAYS** make sure the trailer is equipped with a **safety chain**.
- **ALWAYS** properly attach trailer’s safety chains to towing vehicle.
- **ALWAYS** make sure the vehicle and trailer directional, backup, brake and trailer lights are connected and working properly.
- DOT Requirements include the following:
  - Connect and test electric brake operation.
  - Secure portable power cables in cable tray with tie wraps.
- The maximum speed for highway towing is **55 MPH** unless posted otherwise. Recommended off-road towing is not to exceed **15 MPH** or less depending on type of terrain.
- Avoid sudden stops and starts. This can cause skidding, or jack-knifing. Smooth, gradual starts and stops will improve towing.
- Avoid sharp turns to prevent rolling.
- Trailer should be adjusted to a level position at all times when towing.
- Raise and lock trailer wheel stand in up position when towing.
- Place **chock blocks** underneath wheel to prevent **rolling** while parked.
- Place **support blocks** underneath the trailer’s bumper to prevent **tipping** while parked.
- Use the trailer’s swivel jack to adjust the trailer height to a level position while parked.

# SAFETY INFORMATION

## ELECTRICAL SAFETY

### DANGER

- **DO NOT** touch output terminals during operation. Contact with output terminals during operation can cause **electrocution, electrical shock or burn.**



- The electrical voltage required to operate the generator can cause severe injury or even death through physical contact with live circuits. Turn generator and all circuit breakers **OFF** before performing maintenance on the generator or making contact with output terminals.

- **NEVER** insert any objects into the output receptacles during operation. This is extremely dangerous. The possibility exists of **electrical shock, electrocution or death.**



- Backfeed to a utility system can cause **electrocution** and/or property damage. **NEVER** connect the generator to a building's electrical system without a transfer switch or other approved device. All installations should be performed by a **licensed electrician** in accordance with all applicable laws and electrical codes. Failure to do so could result in electrical shock or burn, causing **serious injury or even death.**



## Power Cord/Cable Safety

### DANGER

- **NEVER** let power cords or cables **lay in water.**
- **NEVER stand in water** while AC power from the generator is being transferred to a load.
- **NEVER** use **damaged** or **worn** cables or cords when connecting equipment to generator. Inspect for cuts in the insulation.
- **NEVER** grab or touch a live power cord or cable with wet hands. The possibility exists of **electrical shock, electrocution or death.**

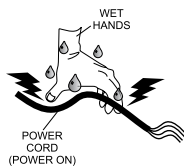

- Make sure power cables are securely connected to the generator's output receptacles. Incorrect connections may cause electrical shock and damage to the generator.

### NOTICE

- **ALWAYS** make certain that proper power or extension cord has been selected for the job. See Cable Selection Chart in this manual.

## Grounding Safety

### DANGER

- **ALWAYS** make sure that electrical circuits are properly grounded to a suitable earth ground (ground rod) per the National Electrical Code (NEC) and local codes before operating generator. **Severe injury or death by electrocution** can result from operating an ungrounded generator.

- **NEVER** use gas piping as an electrical ground.

## BATTERY SAFETY

### DANGER

- **DO NOT** drop the battery. There is a possibility that the battery will explode.
- **DO NOT** expose the battery to open flames, sparks, cigarettes, etc. The battery contains combustible gases and liquids. If these gases and liquids come into contact with a flame or spark, an explosion could occur.

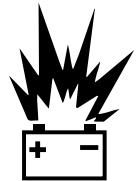

### WARNING

- **ALWAYS** wear safety glasses when handling the battery to avoid eye irritation. The battery contains acids that can cause injury to the eyes and skin.
- Use well-insulated gloves when picking up the battery.
- **ALWAYS** keep the battery charged. If the battery is not charged, combustible gas will build up.
- **ALWAYS** recharge the battery in a well-ventilated environment to avoid the risk of a dangerous concentration of combustible gasses.



# SAFETY INFORMATION

- If the battery liquid (dilute sulfuric acid) comes into contact with **clothing or skin**, rinse skin or clothing immediately with plenty of water.
- If the battery liquid (dilute sulfuric acid) comes into contact with **eyes**, rinse eyes immediately with plenty of water and contact the nearest doctor or hospital to seek medical attention.

## CAUTION

- **ALWAYS** disconnect the **NEGATIVE battery terminal** before performing service on the generator.
- **ALWAYS** keep battery cables in good working condition. Repair or replace all worn cables.

## ENVIRONMENTAL SAFETY/DECOMMISSIONING

### NOTICE

Decommissioning is a controlled process used to safely retire a piece of equipment that is no longer serviceable. If the equipment poses an unacceptable and unreparable safety risk due to wear or damage or is no longer cost effective to maintain (beyond life-cycle reliability) and is to be decommissioned (demolition and dismantlement), be sure to follow rules below.

- **DO NOT** pour waste or oil directly onto the ground, down a drain or into any water source.
- Contact your country's Department of Public Works or recycling agency in your area and arrange for proper disposal of any electrical components, waste or oil associated with this equipment.
- When the life cycle of this equipment is over, remove battery and bring to appropriate facility for lead reclamation. Use safety precautions when handling batteries that contain sulfuric acid.
- When the life cycle of this equipment is over, it is recommended that the trowel frame and all other metal parts be sent to a recycling center.



Metal recycling involves the collection of metal from discarded products and its transformation into raw materials to use in manufacturing a new product.

Recyclers and manufacturers alike promote the process of recycling metal. Using a metal recycling center promotes energy cost savings.

## EMISSIONS INFORMATION

### NOTICE

The diesel engine used in this equipment has been designed to reduce harmful levels of carbon monoxide (CO), hydrocarbons (HC) and nitrogen oxides (NOx) contained in diesel exhaust emissions.

This engine has been certified to meet US EPA Evaporative emissions requirements in the installed configuration.

Attempting to modify or make adjustments to the engine emission system by unauthorized personnel without proper training could damage the equipment or create an unsafe condition.

Additionally, modifying the fuel system may adversely affect evaporative emissions, resulting in fines or other penalties.

### Emission Control Label

The emission control label is an integral part of the emission system and is strictly controlled by regulations.

The label must remain with the engine for its entire life.

If a replacement emission label is needed, please contact your authorized engine distributor.

# SPECIFICATIONS

<b>Table 1. Generator Specifications</b>		
<b>Model</b>	DCA25USI4CAN	
<b>Type</b>	Revolving field, self ventilated, drip-proof, single-bearing generator	
<b>Armature Connection</b>	<b>Star with Neutral</b>	<b>Zigzag</b>
<b>Phase</b>	3	Single
<b>Standby Output</b>	27.5 kVA (22.0 KW)	15.8 KW
<b>Prime Output</b>	25kVA (20 KW)	14.4 KW
<b>Power Factor</b>	0.8	1.0
<b>Voltage</b>	240 or 480V	240V/120V
<b>Frequency</b>	60 Hz	
<b>Speed</b>	1800 rpm	
<b>Aux. AC Power</b>	Single Phase, 60 Hz	
<b>Aux. Voltage/Output</b>	4.8 Kw (2.4 kW x 2)	
<b>Dry Weight</b>	1,808 lbs. (820 kg.)	
<b>Wet Weight</b>	2,132 lbs. (967 kg.)	
<b>Table 2. Engine Specifications</b>		
<b>Model</b>	ISUZU BV-4LE2-NYGD02 Tier 4i	
<b>Type</b>	4 cycle, water-cooled, direct injection	
<b>No. of Cylinders</b>	4 cylinders	
<b>Bore x Stroke</b>	3.35 in. x3.78 in. (85 mm x 96 mm)	
<b>Displacement</b>	132 cu. in. (2,179 cc)	
<b>Rated Output</b>	30.6 HP at 1800 rpm	
<b>Starting</b>	Electric	
<b>Coolant Capacity</b>	1.7 gal. (6.4 liters)	
<b>Lube Oil Capacity</b>	2.25 gal. (8.5 liters)	
<b>Fuel Type</b>	#2 Diesel Fuel	
<b>Fuel Tank Capacity</b>	41.7 gal. (158 Liters)	
<b>Fuel Consumption</b>	1.66 gal. (6.3 L)/hr at <b>full load</b>	1.21 gal. (4.6 L)/hr at <b>3/4 load</b>
	0.85 gal. (3.2 L)/hr at <b>1/2 load</b>	0.58 gal. (2.2 L)/hr at <b>1/4 load</b>
<b>Battery</b>	12V-53 Ah x 1	

# DIMENSIONS

**TOP VIEW**

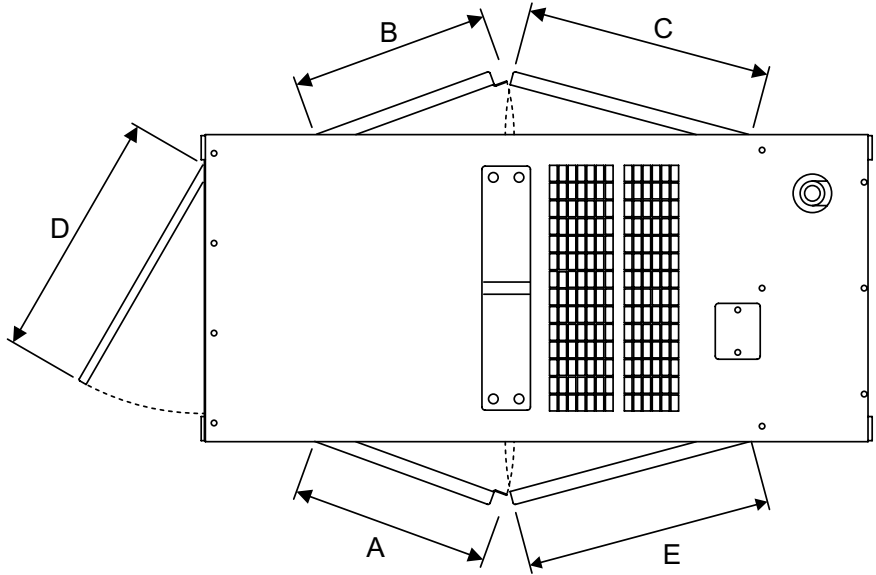

**SIDE VIEW**

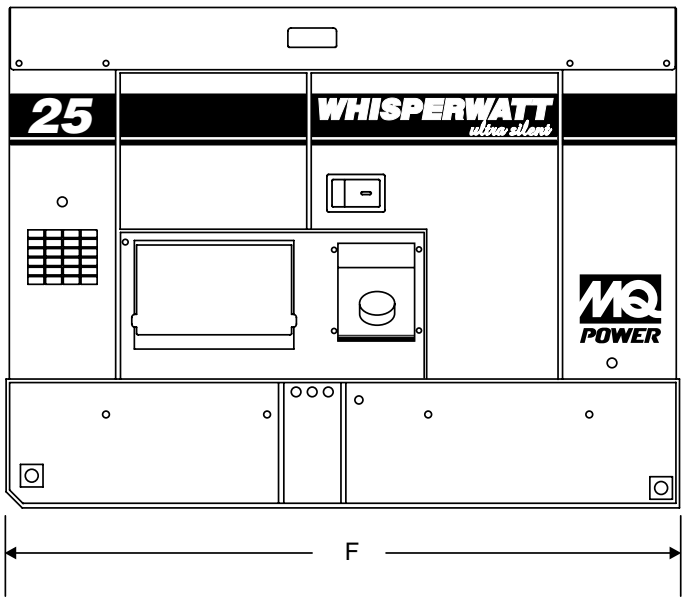

**FRONT VIEW**

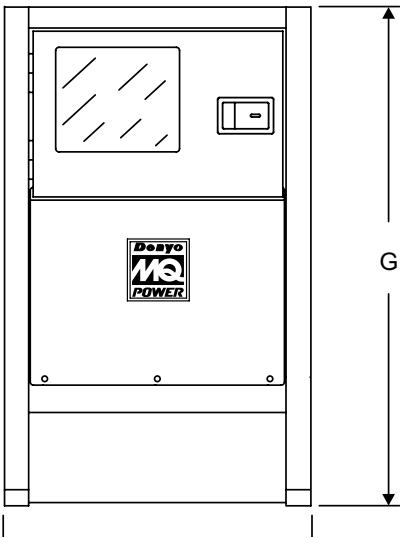

**Figure 1. Dimensions**

Table 3. Dimensions			
Reference Letter	Dimension in. (mm)	Reference Letter	Dimension in. (mm)
A	22.64 in. (575 mm.)	F	70.47 in. (1,790 mm.)
B	20.87 in. (530 mm.)	G	49.61 in. (1,260 mm.)
C	27.36 in. (695 mm.)	H	31.1 in. (790 mm.)
D	24.8 in. (630 mm.)		
E	25.59 in. (650 mm.)		

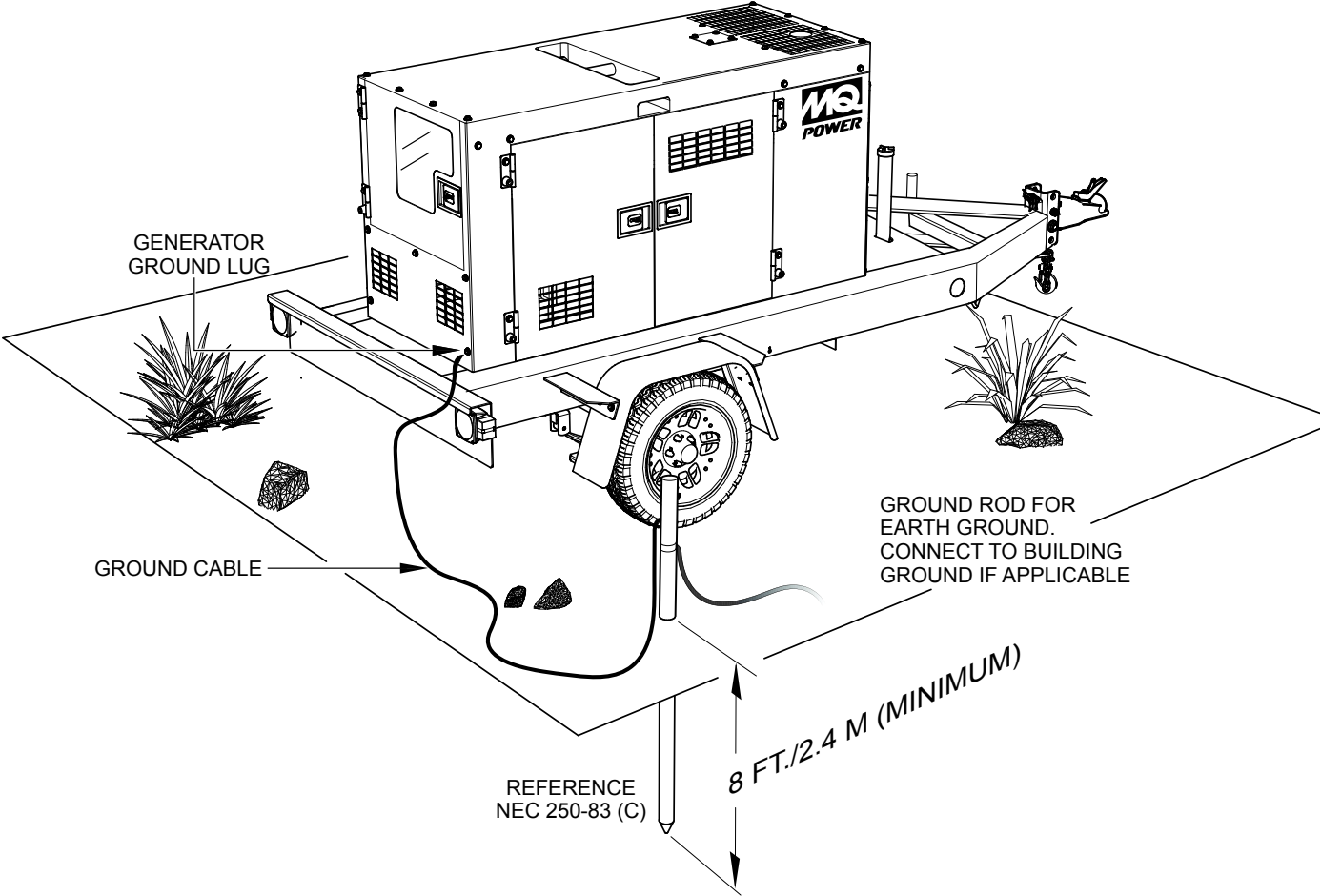

**Figure 2. Typical Generator Grounding Application**

## OUTDOOR INSTALLATION

Install the generator in a area that is free of debris, bystanders, and overhead obstructions. Make sure the generator is on secure level ground so that it cannot slide or shift around. Also install the generator in a manner so that the exhaust will not be discharged in the direction of nearby homes.

The installation site must be relatively free from moisture and dust. All electrical equipment should be protected from excessive moisture. Failure to do will result in deterioration of the insulation and will result in short circuits and grounding.

Foreign materials such as dust, sand, lint and abrasive materials have a tendency to cause excessive wear to engine and alternator parts.

### CAUTION

Pay close attention to ventilation when operating the generator inside tunnels and caves. The engine exhaust contains noxious elements. Engine exhaust must be routed to a ventilated area.

## INDOOR INSTALLATION

Exhaust gases from diesel engines are extremely poisonous. Whenever an engine is installed indoors the exhaust fumes must be vented to the outside. The engine should be installed at least two feet from any outside wall. Using an exhaust pipe which is too long or too small can cause excessive back pressure which will cause the engine to heat excessively and possibly burn the valves.

## MOUNTING

The generator must be mounted on a solid foundation (such as concrete) and set firmly on the foundation to isolate vibration of the generator when it is running. The generator must set at least 6 inches above the floor or grade level (in accordance to NFPA 110, Chapter 5-4.1). **DO NOT** remove the metal skids on the bottom of the generator. They are to resist damage to the bottom of the generator and to maintain alignment.

## GENERATOR GROUNDING

To guard against electrical shock and possible damage to the equipment, it is important to provide a good **EARTH** ground.

Article 250 (Grounding) of the National Electrical Code (NEC) provides guide lines for proper grounding and specifies that the cable ground shall be connected to the grounding system of the building as close to the point of cable entry as practical.

NEC articles 250-64(b) and 250-66 set the following grounding requirements:

1. Use one of the following wire types to connect the generator to earth ground.
  - a. Copper - 8 AWG (5.3 mm<sup>2</sup>)
  - b. Aluminum - 6 AWG (8.4 mm<sup>2</sup>)
2. When grounding the generator (Figure 2) connect the ground cable between the lock washer and the nut on the generator and tighten the nut fully. Connect the other end of the ground cable to earth ground.
3. NEC article 250-52(c) specifies that the earth ground rod should be buried a minimum of 8 ft. into the ground.

### NOTICE

When connecting the generator to any buildings electrical system **ALWAYS** consult with a licensed electrician.

## GENERATOR

This MQ Power generator (Figure 3) is a high quality portable (requires a trailer for transport) power source for telecom sites, lighting facilities, power tools, submersible pumps and other industrial and construction machinery.

## ENGINE OPERATING PANEL

The “Engine Operating Panel” is provided with the following:

- Tachometer
- Water Temperature Gauge
- Warning Lamp
- Pre-Heat Lamp
- Oil Pressure Gauge
- Charging Ammeter Gauge
- Fuel Level Gauge
- Panel Light/Panel Light Switch
- Oil Pressure Alarm Lamp
- Water Temperature Alarm Lamp
- Fuel Filter Water Level Alarm Lamp
- Fuel Leak Detected Alarm Lamp

## GENERATOR CONTROL PANEL

The “Generator Control Panel” is provided with the following:

- Frequency Meter (Hz)
- AC Ammeter (Amps)
- AC Voltmeter (Volts)
- Ammeter Change-Over Switch
- Voltmeter Change-Over Switch
- Voltage Regulator
- 3-Pole, 60 amp Main Circuit Breaker
- “Control Box” (located behind the Gen. Control Panel)
  - Automatic Voltage Regulator
  - Current Transformer
  - Over-Current Relay
  - Starter Relay
  - Voltage Selector Switch

## OUTPUT TERMINAL PANEL

The “Output Terminal Panel” is provided with the following:

- Three 120/240V output receptacles (CS-6369), 50A
- Three auxiliary circuit breakers, 50A
- Two 120V output receptacles (GFCI), 20A
- Two GFCI circuit breakers, 20A
- Five output terminal lugs (3Ø power)

## OPEN DELTA EXCITATION SYSTEM

This generator is equipped with the state of the art “Open-Delta” excitation system. The open delta system consist of an electrically independent winding wound among stationary windings of the AC output section.

There are four connections of the open delta A, B, C and D. During steady state loads, the power from the voltage regulator is supplied from the parallel connections of A to B, A to D, and C to D. These three phases of the voltage input to the voltage regulator are then rectified and are the excitation current for the exciter section.

When a heavy load, such as a motor starting or a short circuit occurs, the automatic voltage regulator (AVR) switches the configuration of the open delta to the series connection of B to C. This has the effect of adding the voltages of each phase to provide higher excitation to the exciter section and thus better voltage response during the application of heavy loads.

The connections of the AVR to the AC output windings are for sensing only. No power is required from these windings. The open-delta design provides virtually unlimited excitation current, offering maximum motor starting capabilities. The excitation does not have a “fixed ceiling” and responds according the demands of the required load.

## ENGINE

This generator unit incorporates an ISUZU BV-4LE2 diesel engine. This engine is designed to meet every performance requirement for the generator. Reference Table 2 for engine specifications.

In keeping with MQ Power’s policy of constantly improving its products, the specifications quoted herein are subject to change without prior notice.

## ELECTRIC GOVERNOR SYSTEM

The electric governor system controls the RPMs of the engine. When the engine demand increases or decreases, the governor system regulates the frequency variation to  $\pm 0.25\%$ .

## EXTENSION CABLES

When electric power is to be provided to various tools or loads at some distance from the generator, extension cords are normally used. Cables should be sized to allow for distance in length and amperage so that the voltage drop between the generator and point of use (load) is held to a minimum. Use the cable selection chart (Table 6) as a guide for selecting proper extension cable size.



# MAJOR COMPONENTS

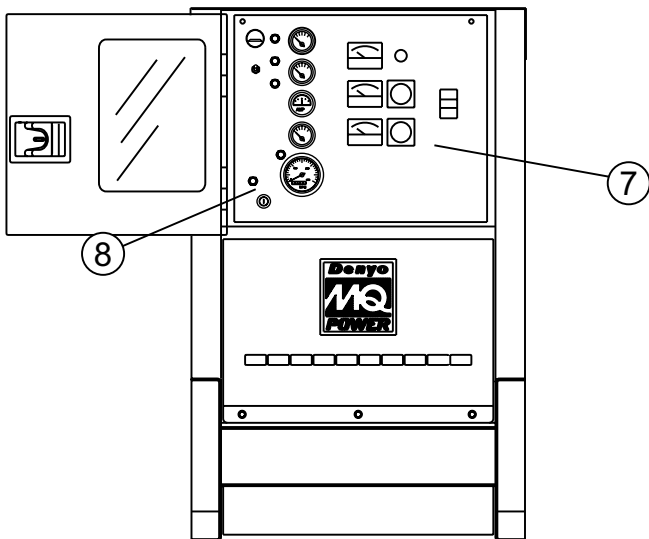
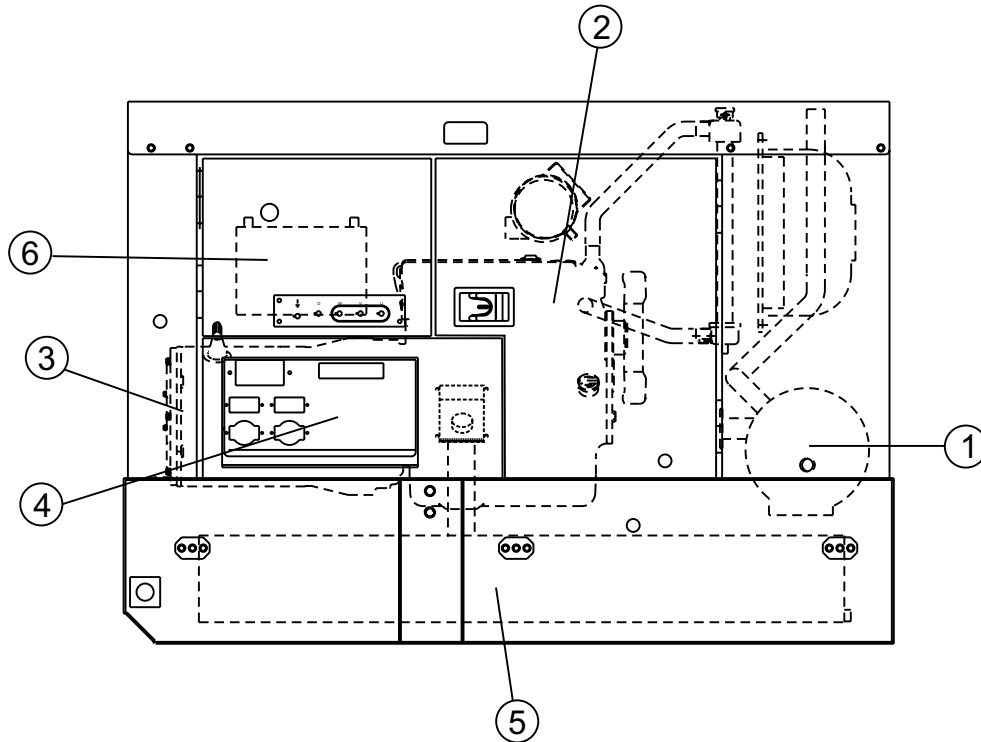
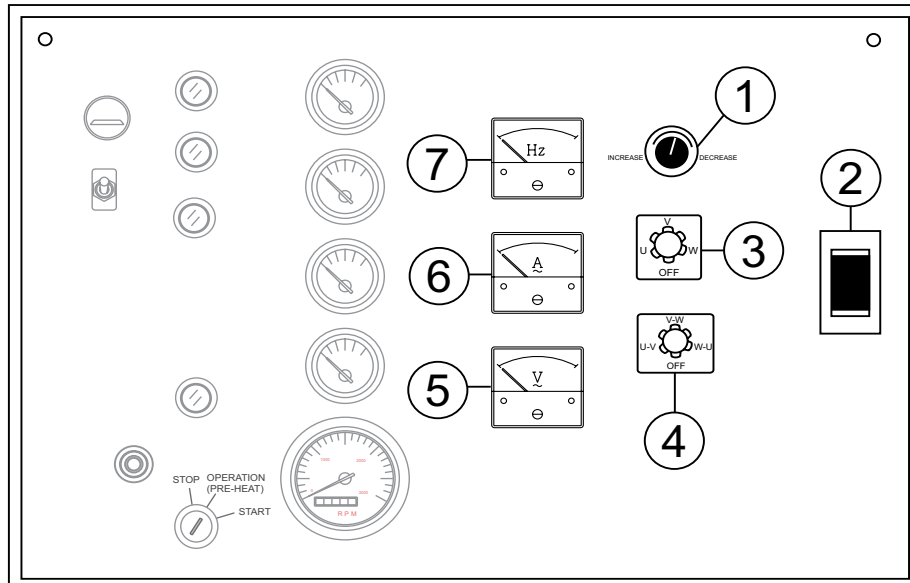

Table 4. Generator Major Components	
ITEM NO.	DESCRIPTION
1	Muffler Assembly
2	Engine Assembly
3	Enclosure Assembly
4	Generator Assembly
5	Output Terminal Assembly
6	Battery Assembly
7	Fuel Tank Assembly
8	Generator Control Panel Assembly
9	Engine Operating Panel Assembly

Figure 3. Major Components

# GENERATOR CONTROL PANEL



**Figure 4. Generator Control Panel**

The definitions below describe the controls and functions of the Generator Control Panel (Figure 4).

1. **Voltage Regulator Control** — Allows  $\pm 15\%$  manual adjustment of the generator's output voltage.
2. **Main Circuit Breaker**—This three-pole, 60A main breaker is provided to protect the the U,V, and W Output Terminal Lugs from overload.
3. **Ammeter Change-Over Switch** — This switch allows the AC ammeter to indicate the current flowing to the load connected to any phase of the output terminals, or to be switched off. This switch does not effect the generator output in any fashion, it is for current reading only.
4. **Voltmeter Change-Over Switch** — This switch allows the AC voltmeter to indicate phase to phase voltage between any two phases of the output terminals or to be switched off.
5. **AC Voltmeter** — Indicates the output voltage present at the U,V, and W Output Terminal Lugs.
6. **AC Ammeter** — Indicates the amount of current the load is drawing from the generator per leg selected by the ammeter phase-selector switch.
7. **Frequency Meter** — Indicates the output frequency in hertz (Hz). Normally 60 Hz.

Located behind the generator control panel is the Generator Control Box. This box contains some of the necessary electronic components required to make the generator function.

The Control Box is equipped with the following major components:

- Over-Current Relay
- Automatic Voltage Regulator (AVR)
- Starter Relay
- Current Transformer
- Voltage Selector Switch
- Main Circuit Breaker

## NOTICE

Remember the **overcurrent relay** monitors the current flowing from the **U,V, and W Output Terminal Lugs** to the load.

In the event of a short circuit or over current condition, it will automatically trip the 60 amp main breaker.

To restore power to the **Output Terminal Panel**, press the reset button on the overcurrent relay and place the **main circuit breaker** in the **closed** position (**ON**).

# ENGINE OPERATING PANEL

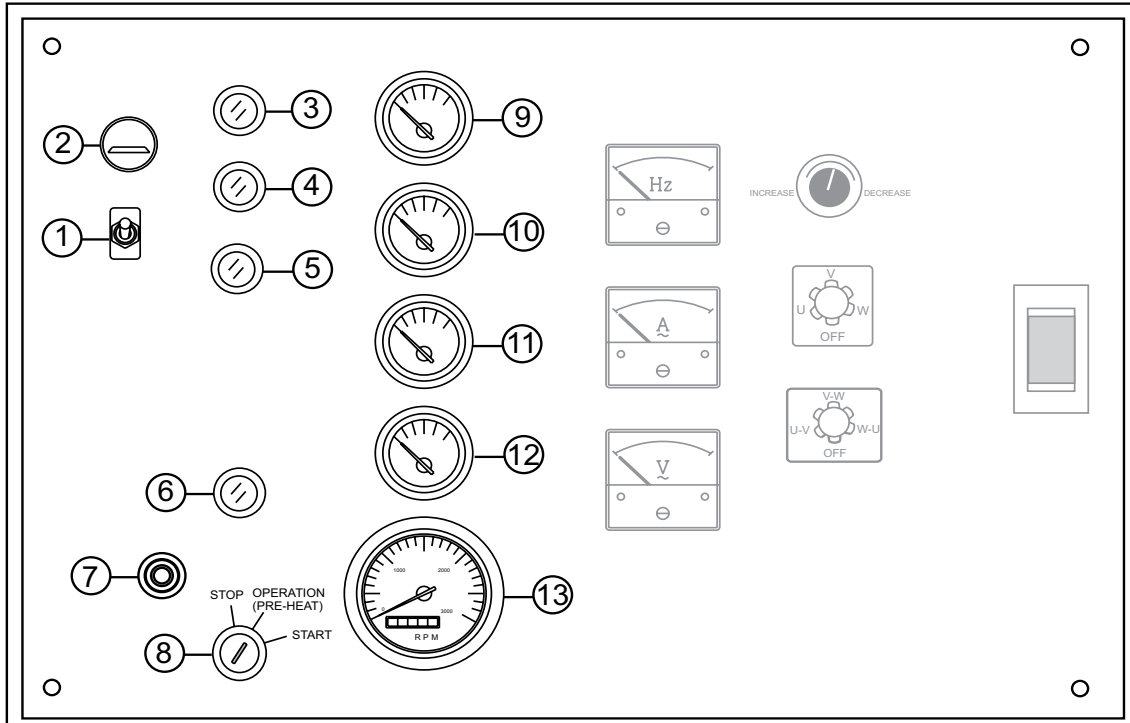

**Figure 5. Engine Operating Panel**

The definitions below describe the controls and functions of the Engine Operating Panel (Figure 5).

1. **Panel Light Switch** — When activated will turn on control panel light.
2. **Panel Light** — Normally used in dark areas or at night time. When activated, panel lights will illuminate. When the generator is not in use be sure to turn the panel light switch to the OFF position.
3. **Oil Pressure Alarm Lamp** — Indicates that the oil pressure is too low or high and will shut down the engine.
4. **Oil Pressure Alarm Lamp** — Indicates that the water temperature is outside of normal range and will shut down the engine.
5. **Fuel Filter Water Lever Alarm Lamp** — Indicates that water level in the fuel level has risen. Drain the water in the fuel filter strainer when this condition occurs.
6. **Fuel Leak Detected Alarm Lamp** — This lamp will illuminate when fluids in the containment have reached high levels
7. **Preheat Lamp** — When the ignition key is placed in the preheat position, this lamp will illuminate to indicate preheating of the engine glow plugs. When the lamp turns off, this indicates that the preheat cycle is complete and the engine can be started.
8. **Ignition Switch** — Three position switch, stop, operation and start. Insert ignition key to start and stop engine.
9. **Oil Pressure Gauge** — Normal operation should be between 28 ~71 psi (193 ~490 kPa). When starting the generator the oil pressure may read a bit higher, but after the engine warms up the oil pressure should return to normal.
10. **Water Temperature Gauge** — During normal operation this gauge be should read between 165° ~ 203°F (74° ~ 95°C).
11. **Charging Ammeter Gauge** — Indicates the current being supplied by the engine's alternator which provides current for generator's control circuits and battery charging system.
12. **Fuel Gauge** — Indicates amount of diesel fuel available
13. **Tachometer** — Indicates engine speed in RPM's for 60 Hz operation. This meter should indicate 1800 RPM's when the rated load is applied. In addition a built in hour meter will record the number of operational hours that the generator has been in use

# OUTPUT TERMINAL PANEL FAMILIARIZATION

## OUTPUT TERMINAL PANEL

The Output Terminal Panel (Figure 6) shown below is located on the right-hand side (left from control panel) of the generator. Lift up on the cover to gain access to receptacles and terminal lugs.

### NOTICE

Terminal legs "O" and "Ground" are considered bonded grounds.

## OUTPUT TERMINAL FAMILIARIZATION

The "Output Terminal Panel" (Figure 6) is provided with the following:

- Three 120/240V output receptacles @ 50 amp
- Three Circuit Breakers @ 50 amps
- Two 120V GFCI receptacles @ 20 amp
- Two GFCI Circuit Breakers @ 20 amps
- Five Output Terminal Lugs ( U, V, W, O, Ground)

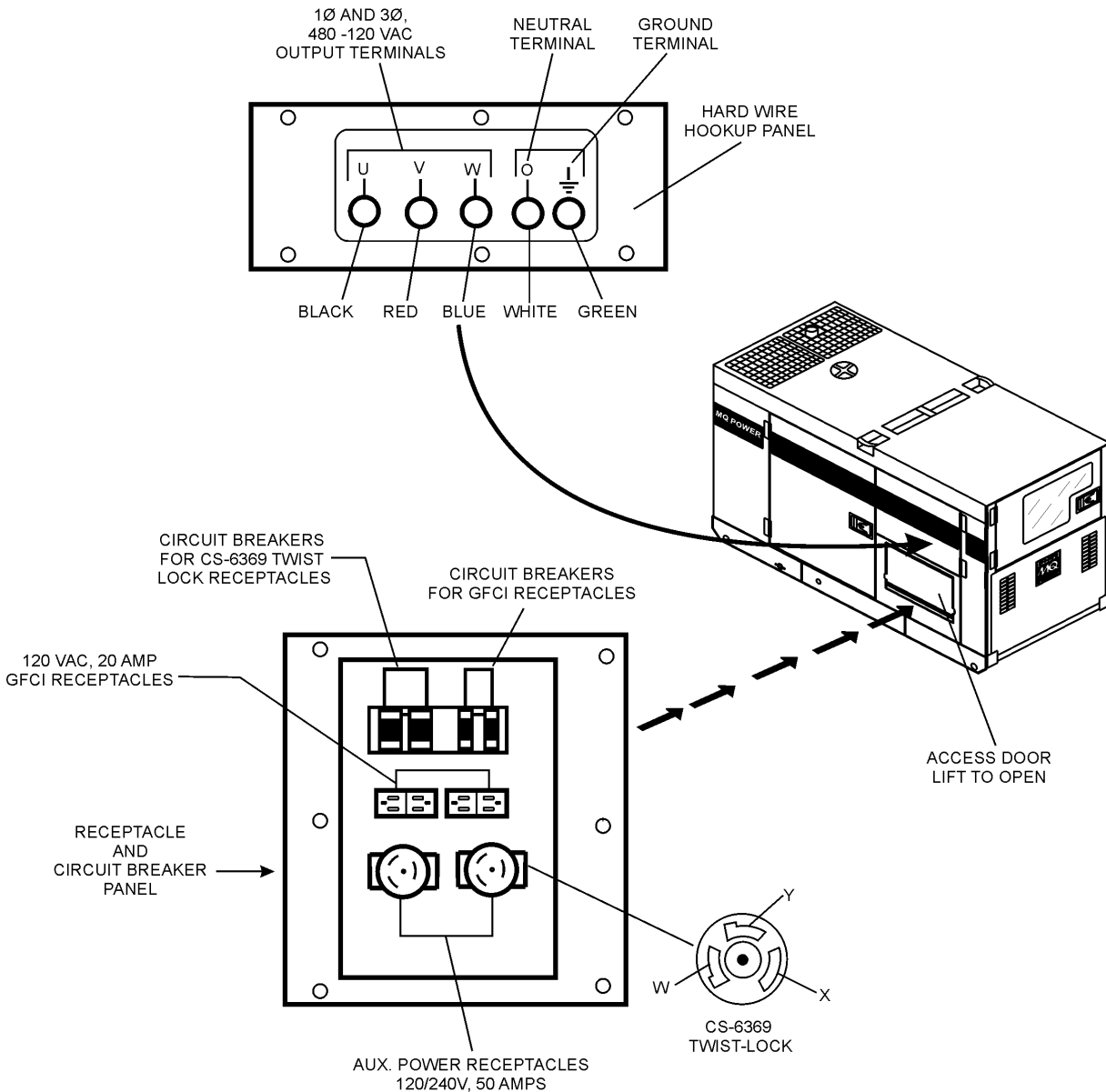

Figure 6. Output Terminal Panel

# OUTPUT TERMINAL PANEL FAMILIARIZATION

## 120 VAC GFCI Receptacles

There are two 120 VAC, 20 amp GFCI (Duplex Nema 5-20R) receptacles provided on the output terminal panel. These receptacles can be accessed in **any voltage selector switch** position. Each receptacle is protected by a 20 amp circuit breaker. These breakers are located directly above the GFCI receptacles. Remember the load output (current) of both GFCI receptacles is dependent on the load requirements of the U, V, and W output terminal lugs.

Pressing the **reset** button resets the GFCI receptacle after being tripped. Pressing the **test button** (Figure 7) in the center of the receptacle will check the GFCI function. Both receptacles should be tested at least once a month.

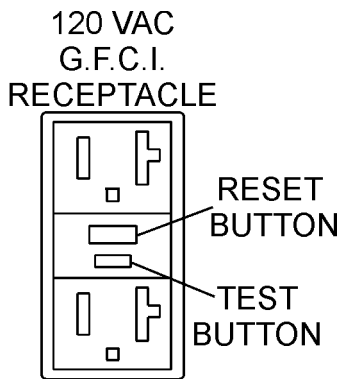

Figure 7. G.F.C.I. Receptacle

## Twist Lock Dual Voltage 120/240 VAC Receptacles

There are two 120/240V, 50 amp auxiliary twist-lock (CS-6369) receptacles (Figure 8) provided on the output terminal panel. These receptacles can **only** be accessed when the voltage selector switch is placed in the **single-phase 240/120 position**.

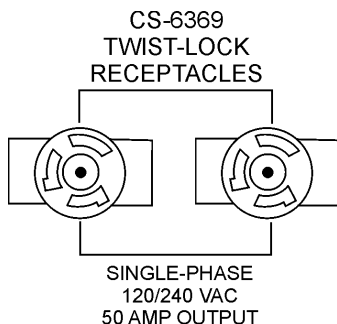

Figure 8. 120/240V Twist-Lock Auxiliary Receptacles

Each auxiliary receptacle is protected by a 50 amp circuit breaker. These breakers are located directly above the GFCI receptacles. Remember the load output (current) on all three receptacles is dependent on the load requirements of the **output terminal lugs**.

Turn the **voltage regulator control knob** (Figure 9) on the control panel to obtain the desired voltage. Turning the knob clockwise will **increase** the voltage, turning the knob counter-clockwise will **decrease** the voltage.



Figure 9. Voltage Regulator Control Knob

## Removing the Plastic Face Plate (Hard Wire Hookup Panel)

The **output terminal lugs** are protected by a plastic face plate cover (Figure 10). Un-screw the securing bolts and lift the plastic terminal cover to gain access to the terminal enclosure.

After the load wires have been securely attached to the terminal lugs, reinstall the plastic face plate.

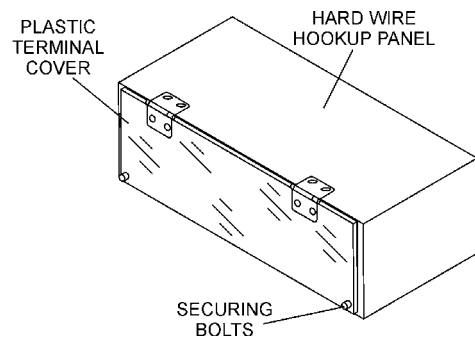

Figure 10. Plastic Face Plate (Output Terminal Lugs)

# OUTPUT TERMINAL PANEL FAMILIARIZATION

## Connecting Loads

Loads can be connected to the generator by the **output terminal lugs** or the convenience receptacles (Figure 11). Make sure to read the operation manual before attempting to connect a load to the generator.

To protect the output terminals from overload, a 3-pole, 60 amp **main** circuit breaker is provided. Make sure to switch **ALL** circuit breakers to the **OFF** position prior to starting the engine.

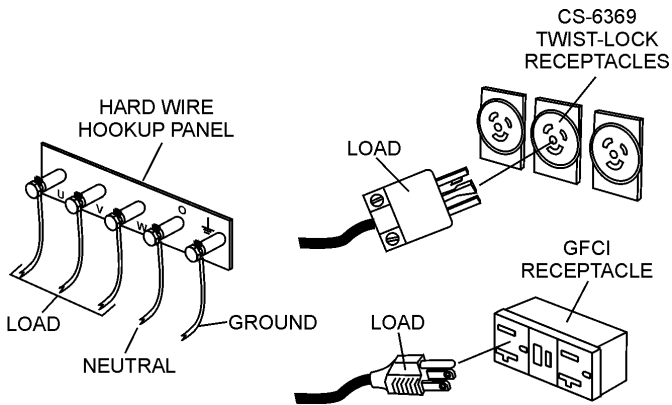

Figure 11. Connecting Loads

## Over Current Relay

An **over current relay** (Figure 12) is connected to the main circuit breaker. In the event of an overload, both the circuit breaker and the over current relay may trip. If the circuit breaker can not be reset, the **reset button** on the over current relay must be pressed. The over current relay is located in the control box.

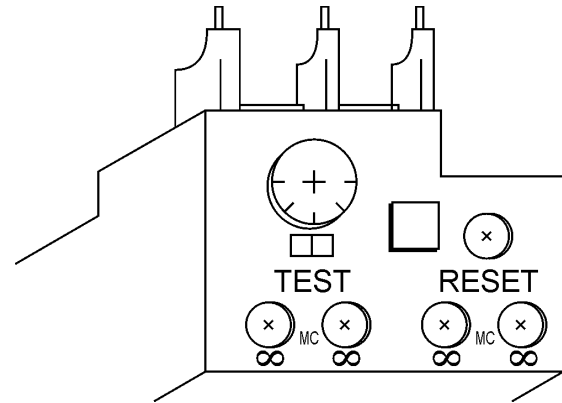

Figure 12. Over Current Relay

# LOAD APPLICATION

## SINGLE PHASE LOAD

Always be sure to check the nameplate on the generator and equipment to insure the wattage, amperage, frequency, and voltage requirements are satisfactorily supplied by the generator for operating the equipment.

Generally, the wattage listed on the nameplate of the equipment is its rated output. Equipment may require 130—150% more wattage than the rating on the nameplate, as the wattage is influenced by the efficiency, power factor and starting system of the equipment.

### NOTICE

If wattage is not given on the equipment's name plate, approximate wattage may be determined by multiplying nameplate voltage by the nameplate amperage.

$$\text{WATTS} = \text{VOLTAGE} \times \text{AMPERAGE}$$

The power factor of this generator is 0.8. See Table 5 below when connecting loads.

**Table 5. Power Factor By Load**

Type of Load	Power Factor
Single-phase induction motors	0.4-0.75
Electric heaters, incandescent lamps	1.0
Fluorescent lamps, mercury lamps	0.4-0.9
Electronic devices, communication equipment	1.0
Common power tools	0.8

**Table 6. Cable Selection (60 Hz, Single Phase Operation)**

Current in Amperes	Load in Watts		Maximum Allowable Cable Length			
	At 100 Volts	At 200 Volts	#10 Wire	#12 Wire	#14 Wire	#16 Wire
2.5	300	600	1000 ft.	600 ft.	375 ft.	250 ft.
5	600	1200	500 ft.	300 ft.	200 ft.	125 ft.
7.5	900	1800	350 ft.	200 ft.	125 ft.	100 ft.
10	1200	2400	250 ft.	150 ft.	100 ft.	
15	1800	3600	150 ft.	100 ft.	65 ft.	
20	2400	4800	125 ft.	75 ft.	50 ft.	

CAUTION: Equipment damage can result from low voltage

## THREE PHASE LOAD

When calculating the power requirements for 3-phase power use the following equation:

$$\text{KVA} = \frac{\text{VOLTAGE} \times \text{AMPERAGE} \times 1.732}{1000}$$

### NOTICE

If 3Ø load (kVA) is not given on the equipment nameplate, approximate 3Ø load may be determined by multiplying voltage by amperage by 1.732.

### NOTICE

Motors and motor-driven equipment draw much greater current for starting than during operation.

An inadequate size connecting cable which cannot carry the required load can cause a voltage drop which can burn out the appliance or tool and overheat the cable. See Table 6.

- When connecting a resistance load such as an incandescent lamp or electric heater, a capacity of up to the generating set's rated output (kW) can be used.
- When connecting a fluorescent or mercury lamp, a capacity of up to the generating set's rated output (kW) multiplied by 0.6 can be used.
- When connecting an electric drill or other power tools, pay close attention to the required starting current capacity.

When connecting ordinary power tools, a capacity of up to the generating set's rated output (kW) multiplied by 0.8 can be used.

### DANGER

Before connecting this generator to any building's electrical system, a **licensed electrician** must install an **isolation (transfer) switch**. Serious damage to the building's electrical system may occur without this transfer switch.

# GENERATOR OUTPUTS

## GENERATOR OUTPUT VOLTAGES

A wide range of voltages are available to supply voltage for many different applications. Voltages are selected by using the **voltage selector** switch (Figure 13). To obtain some of the voltages as listed in Table 7 (see below) will require a fine adjustment using the **voltage regulator (VR) control knob** located on the control panel.

### Voltage Selector Switch

The voltage selector switch (Figure 13) is located above the output terminal panel's Hard Wire Hook-up Panel. It has been provided for ease of voltage selection.

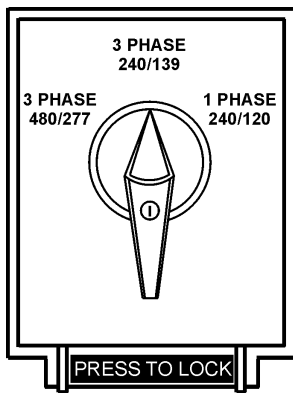

Figure 13. Voltage Change-Over Switch

### Voltage Selector Switch Locking Button

To lock the voltage selector switch, **press and hold the red button** located at the bottom of the switch. While holding the red button down, insert a pad lock into the hole next to the button to retain it in the inward locked position. When the lock is removed, the red button is spring loaded and will return to its normal outward unlocked position.

### CAUTION

**NEVER** change the position of the **voltage selector switch** while the engine is running. **ALWAYS** place circuit breaker in the **OFF** position before selecting voltage.

Table 7. Voltages Available

	208V	220V	240V	416V	440V	480V
Three Phase (Switchable)						
Single Phase (Switchable)	120V	1127V	139V	240V	254V	277V

## Generator Amperage

Table 8 shows the **maximum** amps the generator can provide. **DO NOT** exceed the maximum amps as listed..

Table 8. Generator Maximum Amps

Rated Voltage	Maximum Amps
1Ø 120 Volt	55.5 amps (4 wire)
1Ø 240 Volt	27.8 amps (4 wire)
3Ø 240 Volt	60 amps
3Ø 480 Volt	30 amps

## GFCI Receptacle Load Capability

The load capability of the GFCI receptacles is directly related to the voltage being supplied at either the output terminals or the 2 twist lock auxiliary receptacles.

Tables 9 and 10 show what amount of current is available at the GFCI receptacles when the output terminals and twist lock receptacles are in use. Be careful that your load does not to exceed the available current capability at the receptacles.

Table 9. 1Ø GFCI Receptacle Load Capacity

KW in Use Twist Lock (C6369)	Available Load Current (Amps)
1Ø 240/120V	GFCI Duplex 5-20R 120V
14.4	0
13.2	5 amps/receptacle
12.0	10 amps/receptacle
10.8	15 amps/receptacle
9.6	20 amps/receptacle

Table 10. 3Ø Generator Maximum Amps

KVA in Use (UVWO Terminals)	Available Load Current (Amps)
3Ø 240/480V	GFCI Duplex 5-20R 120V
25	0 amps/receptacle
20.8	5 amps/receptacle
16.7	10 amps/receptacle
12.5	15 amps/receptacle
8.4	20 amps/receptacle



# GENERATOR OUTPUTS/GAUGE READING

## HOW TO READ THE AC AMMETER AND AC VOLTAGE GAUGES

The AC ammeter and AC voltmeter gauges are controlled by the AC ammeter and AC voltmeter change-over switches.

Both of these switches are located on the control panel and **DO NOT** effect the generator output. They are provided to help observe how much power is being supplied, produced at the UVWO terminals lugs.

Before taking a reading from either gauge, set the **Voltage Selector Switch** (Figure 14) to the position which produces the required voltage (For example, for 3Ø 240V, choose the center 3Ø 240/139V position on the voltage selector switch).

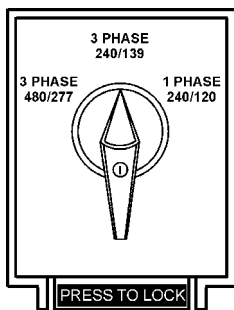

Figure 14. Voltage Selector Switch  
240/139V 3Ø Position

### NOTICE

For 3Ø 208V/1Ø,120V, place the Voltage Selector Switch in the 3 Phase 240/139 position.

## AC Voltmeter Gauge Reading

Place the **AC Voltmeter Change-Over Switch** (Figure 15) in the W-U position and observe the phase to phase voltage reading between the W and U terminals as indicated on the **AC Voltmeter Gauge** (Figure 16)

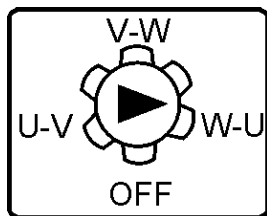

Figure 15. AC Voltmeter  
Change-Over Switch

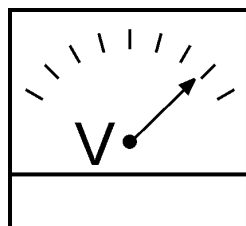

Figure 16. AC Voltmeter  
Gauge

## AC Ammeter Gauge Reading

Place the **AC Ammeter Change-Over Switch** (Figure 17) in the U position and observe the current reading (load drain) on the U terminal as indicated on the **AC Ammeter Gauge** (Figure 18). This process can be repeated for terminals V and W.

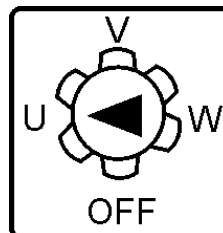

Figure 17. AC Ammeter  
Change-Over Switch

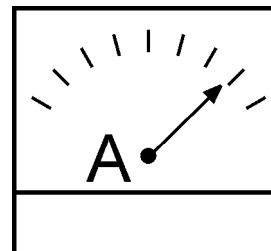

Figure 18. AC Ammeter  
(Amp Reading on U Lug)

### NOTICE

The **ammeter** gauge will only show a reading when the **Output Terminal Lugs** are connected to a load and in use.

# OUTPUT TERMINAL PANEL CONNECTIONS

## UVWO TERMINAL OUTPUT VOLTAGES

Various output voltages can be obtained using the UVWO output terminal lugs. The voltages at the terminals are dependent on the position of the **Voltage Selector Switch** and the adjustment of the **Voltage Regulator Control Knob**.

Remember the voltage selector switch determines the **range** of the output voltage. The voltage regulator (VR) allows the user to increase or decrease the selected voltage.

### 3Ø-240/139 UVWO Terminal Output Voltages

1. Place the voltage selector switch in the 3Ø 240/139 position as shown in Figure 19.

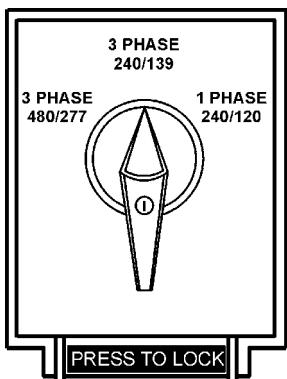

**Figure 19. Voltage Selector Switch  
3Ø-240/139V Position**

2. Connect the load wires to the UVWO terminals as shown in Figure 20.

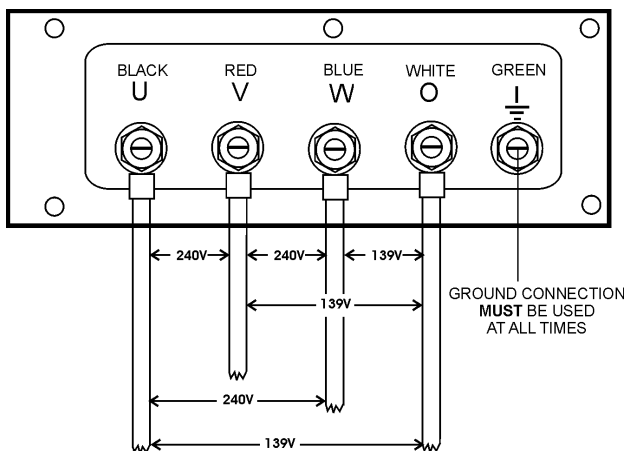

**Figure 20. UVWO Terminal Lugs  
3Ø-240/139V Connections**

3. Turn the voltage regulator knob (Figure 21) clockwise to increase voltage output, turn counterclockwise to decrease voltage output. Use voltage regulator adjustment knob whenever fine tuning of the output voltage is required.

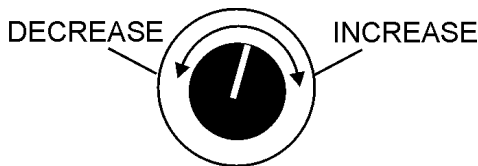

**Figure 21. Voltage Regulator Knob**

### 3Ø-208V/1Ø-120V UVWO Terminal Output Voltages

1. Place the voltage selector switch in the 3Ø 240/139 position as shown in Figure 22.

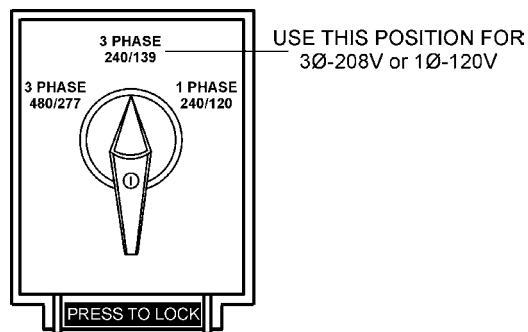

**Figure 22. Voltage Selector Switch  
3Ø-240/139V Position**

2. Connect the load wires to the UVWO terminals as shown in Figure 23.

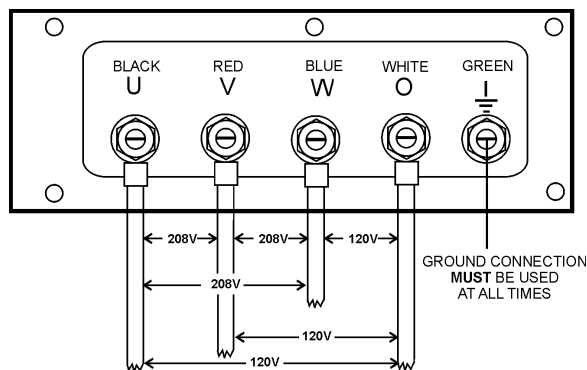

**Figure 23. UVWO Terminal Lugs  
3Ø-208/1Ø-120V Connections Connections**

### NOTICE

To achieve a 3Ø 208V output the voltage selector switch must be in the 3Ø-240/139 position and the voltage regulator must be adjusted to 208V..

# OUTPUT TERMINAL PANEL CONNECTIONS

## 3Ø-480/277V UVWO Terminal Output Voltages

1. Place the voltage selector switch in the 3Ø 480/277 position as shown in Figure 24.

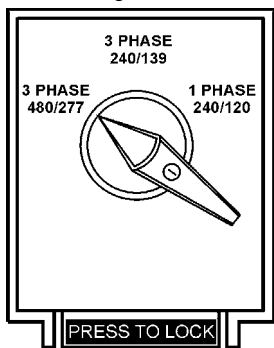

**Figure 24. Voltage Selector Switch  
3Ø-480/277V Position**

2. Connect the load wires to the UVWO terminals as shown in Figure 25.

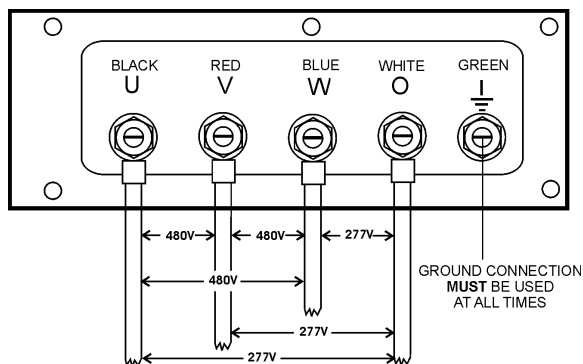
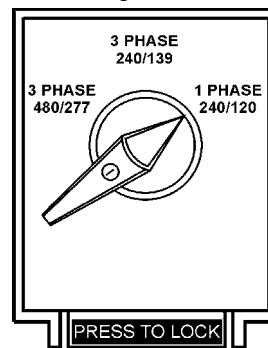

**Figure 25. UVWO Terminal Lugs  
3Ø-440/254V Connections**

3. Turn the voltage regulator knob (Figure 21) clockwise to increase voltage output, turn counterclockwise to decrease voltage output. Use voltage regulator adjustment knob whenever fine tuning of the output voltage is required.

## 1Ø-240/120V UVWO Terminal Output Voltages

1. Place the voltage selector switch in the 1Ø 240/120 position as shown in Figure 26.



**Figure 26. Voltage Selector Switch  
1Ø-240/120V Position**

2. Connect the load wires to the UVWO terminals as shown in Figure 27.

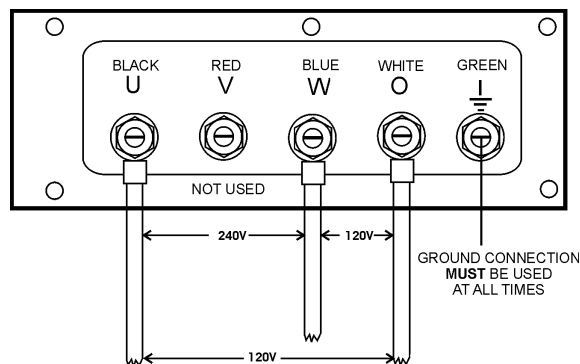

**Figure 27. UVWO Terminal Lugs  
1Ø-200/100V Connections**

3. Turn the voltage regulator knob (Figure 21) clockwise to increase voltage output, turn counterclockwise to decrease voltage output. Use voltage regulator adjustment knob whenever fine tuning of the output voltage is required.

### NOTICE

**ALWAYS** make sure that the connections to the UVWO terminals are **secure** and **tight**. The possibility of arcing exists, that could cause a fire.

# 600 VAC AUTO TRANSFORMER CONNECTIONS

## 3Ø-600V Auto-Transformer

3Ø, 600 VAC can be achieved via the auto-transformer module. This module provides the necessary electronics to convert the 3Ø, 480 VAC input voltage to a 3Ø, 600 VAC output voltage.

The 3Ø, 600 VAC output voltage cannot be achieved unless the voltage selector switch (Figure 29) is placed in the 3Ø, 480/277 position.

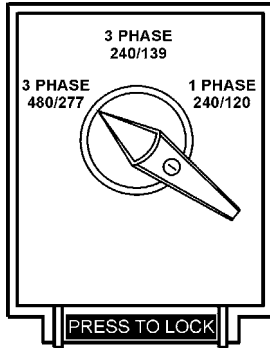

**Figure 28. Voltage Selector Switch  
3Ø-240/139V Position (600 VAC Auto-Transformer)**

## 3Ø-600VAC Load Connections

### **! DANGER**

When connecting the load wires make sure the generator is **OFF**. The possibility of electrocution exists causing severe bodily harm even death!

1. Loosen the latches on the control box enclosure and open the door.
2. Drill a 1-1/2 inch hole at the bottom control box enclosure as shown in Figure 29

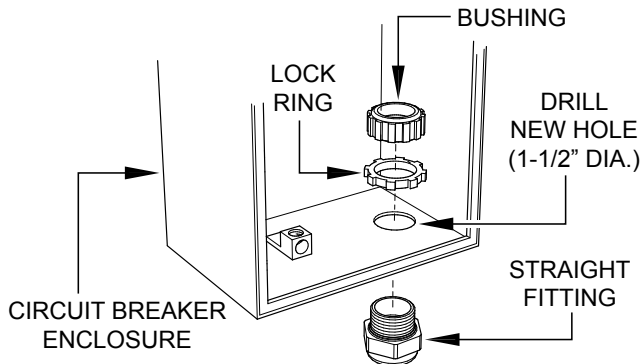

**Figure 29. Control Box Enclosure (Drilling)**

3. After drilling, make sure all shavings and debris have been removed from the enclosure.
4. Install customer supplied conduit, fittings and bushing through enclosure hole opening.
5. Next, route the customer supplied 5 wires through the straight conduit fitting.
6. Connect the 3 load wires (**RED, BLACK and BLUE**) to the load side (bottom) of the circuit breaker, **T1, T2 and T3** respectively. Reference Figure 30

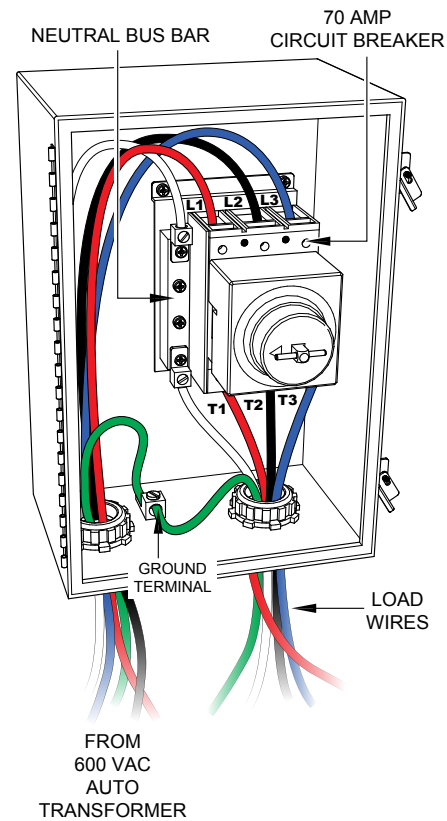

**Figure 30. Control Box Enclosure  
Load Connections**

7. Connect the neutral wire (**WHITE**) to the neutral bus bar.
8. Connect the ground wire (**GREEN**) to the ground terminal.
9. Torque all wires to 45 lbf-in (5 N·m).
10. Once all wires have been securely tightened, close control box enclosure door and securely tighten the control box door latches.

## CIRCUIT BREAKERS

To protect the generator from an overload, a 3-pole, 60 amp, main circuit breaker is provided to protect the **U, V, and W Output Terminals** from overload. In addition two single-pole, 20 amp **GFCI** circuit breakers are provided to protect the GFCI receptacles from overload. Three 50 amp **load** circuit breakers have also been provided to protect the auxiliary receptacles from overload. Make sure to switch **ALL** circuit breakers to the **OFF** position prior to starting the engine.

## LUBRICATION OIL

Fill the engine crankcase with lubricating oil through the filler hole, but **DO NOT** overfill. Make sure the generator is level and verify that the oil level is maintained between the two notches (Figure 31) on the dipstick. See Table 11 for proper selection of engine oil.

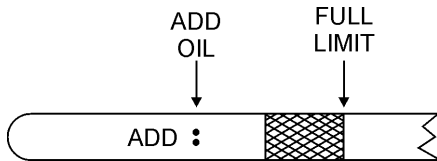

**Figure 31. Engine Oil Dipstick**

When checking the engine oil, be sure to check if the oil is clean. If the oil is not clean, drain the oil by removing the oil drain plug, and refill with the specified amount of oil as outlined in the **ISUZU Engine Owner's Manual**. Oil should be warm before draining.

Other types of motor oils may be substituted if they meet the following requirements:

- API Service Classification CC/SC
- API Service Classification CC/SD
- API Service Classification CC/SE
- API Service Classification CC/SF

Table 11. Recommended Motor Oil		OIL: SAE	
°F	°C		
122	50		
104	40	10W/40	30
86	30		
68	20		
50	10		
32	0		
-14	-10	5W/30	10W/40
-4	-20	ARCTIC OIL	15W/30
-22	-30		10W/30
-40	-40		10W
			20W/40

## FUEL CHECK

**! DANGER**

Fuel spillage on a **hot** engine can cause a **fire** or **explosion**. If fuel spillage occurs, wipe up the spilled fuel completely to prevent fire hazards. **NEVER** smoke around or near the generator.

## Refilling the Fuel System

**! CAUTION**

**ONLY** properly trained personnel who have read and understand this section should refill the fuel tank system.

This generator has an internal fuel tank located inside the base of the generator. (Figure 32). **ALWAYS** fill the fuel tank with clean fresh **#2 diesel fuel**. **DO NOT** fill the fuel tank beyond its capacity.

Pay attention to the fuel tank capacity when replenishing fuel. The fuel tank cap must be closed tightly after filling. Handle fuel in a safety container. If the container does not have a spout, use a funnel. Wipe up any spilled fuel immediately.

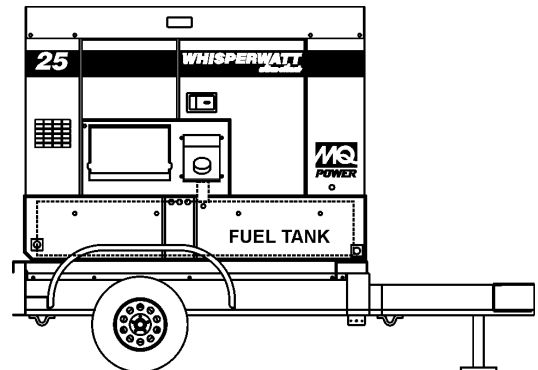

**Figure 32. Internal Fuel Tank System**

# INSPECTION/SETUP

## Refueling Procedure:

### WARNING



**Diesel fuel** and its vapors are dangerous to your health and the surrounding environment. Avoid skin contact and/or inhaling fumes.

1. **Level Tanks** — Make sure fuel cells are level with the ground. Failure to do so will cause fuel to spill from the tank before reaching full capacity (Figure 33).

### CAUTION

**ALWAYS** place trailer on firm level ground before refueling to prevent spilling and maximize the amount of fuel that can be pumped into the tank.

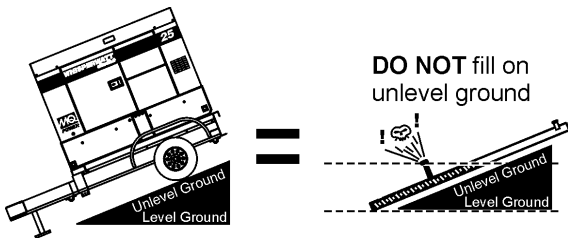

Figure 33. Only Fill on Level Ground

### NOTICE

**ONLY** use #2 diesel fuel when refueling.

2. Open cabinet doors on the “right side” of the generator (from generator control panel position). Remove fuel cap and fill tank (Figure 34).

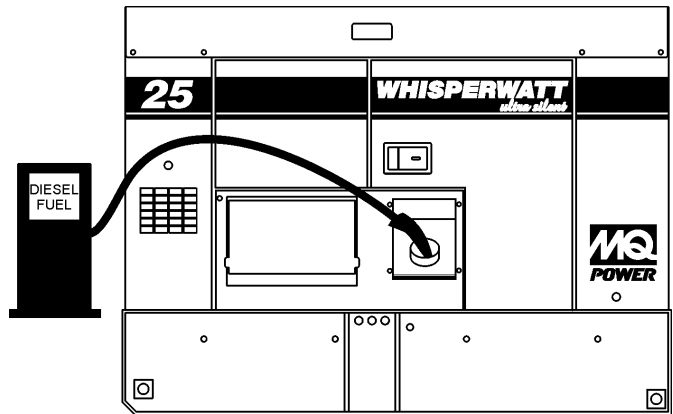

Figure 34. Fueling the Generator

3. **NEVER overfill fuel tank** — It is important to read the fuel gauge when filling trailer fuel tank. **DO NOT** wait for fuel to rise in filler neck (Figure 35).

FUEL GAUGE LOCATED ON CONTROL PANEL

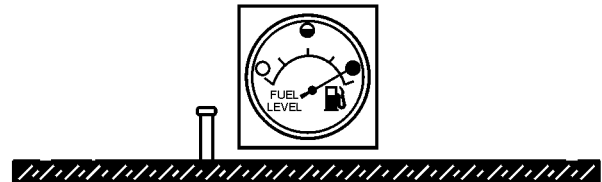

Figure 35. Full Fuel Tank

### CAUTION

**DO NOT OVERFILL** fuel system. Leave room for fuel expansion. Fuel expands when heated (Figure 36).

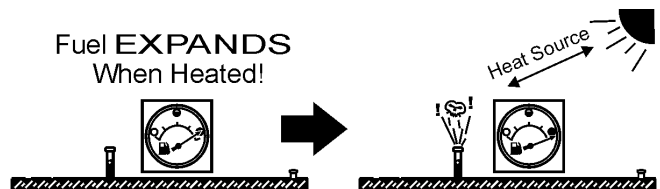



Figure 36. Fuel Expansion

## COOLANT (ANTIFREEZE/SUMMER COOLANT/WATER)

ISUZU recommends ISUZU antifreeze/summer coolant for use in their engines, which can be purchased in concentrate (and mixed with 50% demineralized water) or pre-diluted. See the **ISUZU Engine Owner's Manual** for further details.

**WARNING**



If adding coolant/antifreeze mix to the radiator, **DO NOT** remove the radiator cap until the unit has completely cooled. The possibility of **hot!** coolant exists which can cause severe burns.

Day-to-day addition of coolant is done from the recovery tank. When adding coolant to the radiator, **DO NOT** remove the radiator cap until the unit has completely cooled. See Table 12 for engine, radiator, and recovery tank coolant capacities. Make sure the coolant level in the recovery tank is always between the “H” and the “L” markings.

Table 12. Coolant Capacity	
Engine and Radiator	1.70 gal (6.4 liters)
Reserve Tank	2 quarts (1.9 liters)

### Operation in Freezing Weather

When operating in freezing weather, be certain the proper amount of antifreeze (Table 13) has been added.

Table 13. Anti-Freeze Operating Temperatures				
Vol % Anti-Freeze	Freezing Point		Boiling Point	
	°C	°F	°C	°F
50	-37	-34	108	226

**NOTICE**

When the antifreeze is mixed with water, the antifreeze mixing ratio **must be** less than 50%.

## CLEANING THE RADIATOR

The engine may overheat if the radiator fins become overloaded with dust or debris. Periodically clean the radiator fins with compressed air. Cleaning inside the machine is dangerous, so clean only with the engine turned off and the **negative** battery terminal disconnected.

## AIR CLEANER

Periodic cleaning/replacement is necessary. Inspect it in accordance with the **ISUZU Engine Owner's Manual**.

## FAN BELT TENSION

A slack fan belt may contribute to overheating, or to insufficient charging of the battery. Inspect the fan belt for damage and wear and adjust it in accordance with the **ISUZU Engine Owner's Manual**.

The fan belt tension is proper if the fan belt bends 10 to 15 mm (Figure 37) when depressed with the thumb as shown below.

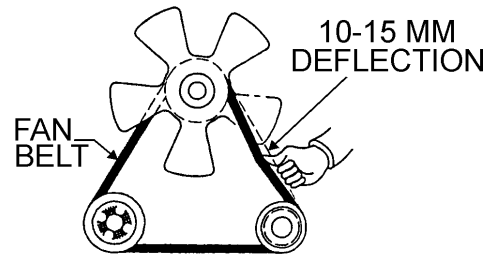



Figure 37. Fan Belt Tension

**CAUTION**



**NEVER** place hands near the belts or fan while the generator set is running.

## BATTERY

This unit is of negative ground **DO NOT** connect in reverse. Always maintain battery fluid level between the specified marks. Battery life will be shortened, if the fluid level are not properly maintained. Add only distilled water when replenishment is necessary.

**DO NOT** over fill. Check to see whether the battery cables are loose. Poor contact may result in poor starting or malfunctions. **Always** keep the terminals firmly tightened. Coating the terminals with an approved battery terminal treatment compound. Replace battery with only recommended type battery.

The battery is sufficiently charged if the specific gravity of the battery fluid is 1.28 (at 68° F). If the specific gravity should fall to 1.245 or lower, it indicates that the battery is dead and needs to be recharged or replaced.

Before charging the battery with an external electric source, be sure to disconnect the battery cables.

### Battery Cable Installation

**ALWAYS** be sure the battery cables (Figure 38) are properly connected to the battery terminals as shown below. The **red cable** is connected to the positive terminal of the battery, and the **black cable** is connected to the negative terminal of the battery.

#### **CAUTION**

**ALWAYS** disconnect the negative terminal **FIRST** and reconnect negative terminal **LAST**.

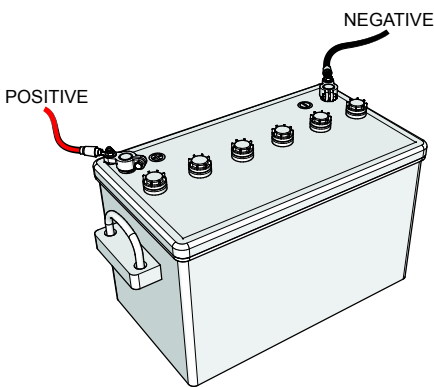

Figure 38. Battery Connections

When connecting battery do the following:

1. **NEVER** connect the battery cables to the battery terminals when the **ignition switch** is in the **START** position. **ALWAYS** make sure that the **ignition switch** is in the **OFF** position when connecting the battery.
2. Place a small amount of battery terminal treatment compound around both battery terminals. This will ensure a good connection and will help prevent corrosion around the battery terminals.

#### **NOTICE**

If the battery cable is connected incorrectly, electrical damage to the generator will occur. Pay close attention to the polarity of the battery when connecting the battery.

#### **CAUTION**

Inadequate battery connections may cause poor starting of the generator, and create other malfunctions.

## ALTERNATOR

The polarity of the alternator is negative grounding type. When an inverted circuit connection takes place, the circuit will be in short circuit instantaneously resulting the alternator failure.

**DO NOT** put water directly on the alternator. Entry of water into the alternator can cause corrosion and damage the alternator.

## WIRING

Inspect the entire generator for bad or worn electrical wiring or connections. If any wiring or connections are exposed (insulation missing) replace wiring immediately.

## PIPING AND HOSE CONNECTION

Inspect all piping, oil hose, and fuel hose connections for wear and tightness. Tighten all hose clamps and check hoses for leaks.

If any hose (**fuel or oil**) lines are defective replace them immediately.



# GENERATOR START-UP PROCEDURE

## BEFORE STARTING

### CAUTION

The engine's exhaust contains harmful emissions. **ALWAYS** have adequate ventilation when operating. Direct exhaust away from nearby personnel.

### WARNING

**NEVER** manually start the engine with the **main, GFCI or auxiliary** circuit breakers in the **ON** (closed) position.

- Place the **main, G.F.C.I., and aux.** circuit breakers (Figure 39) in the **OFF** position prior to starting the engine.

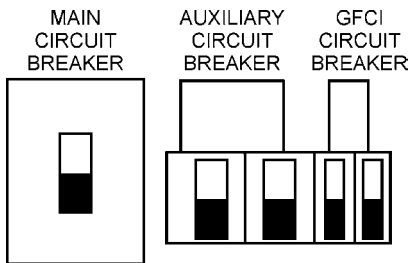

**Figure 39. Main, Aux. and GFCI Circuit Breakers (OFF)**

- Connect the load to the **receptacles** or the **output terminal lugs** as shown in Figure 11. These load connection points can be found on the output terminal panel and the output terminal panel's hard wire hookup panel.
- Tighten terminal nuts securely to prevent load wires from slipping out.
- Close all engine enclosure doors (Figure 40).

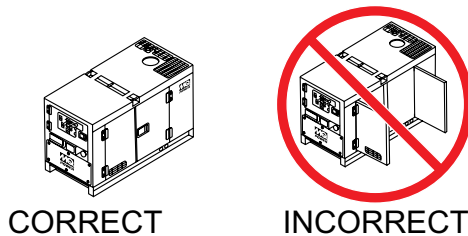

**Figure 40. Engine Enclosure Doors**

## STARTING

- Place the **voltage selector switch** in the desired voltage position (Figure 41)..

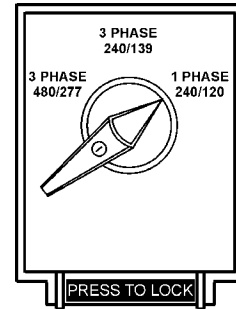

**Figure 41. Voltage Selector Switch**

- Preheat the engine glow plugs by turning the ignition key (Figure 42) to the **OPERATION** position..

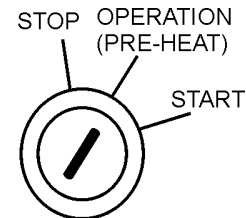

**Figure 42. Ignition Switch**

- When the preheat lamp goes **OFF** (Figure 43), turn the ignition key to the "start" position. Once the engine starts, release the ignition key and allow it to return to the **operation** position.

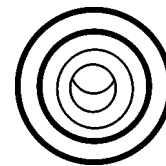

**Figure 43. Pre-Heat Lamp**

- Once the engine starts, let the engine run for 1-2 minutes. Listen for any abnormal noises. If any abnormalities exist, shut down the engine and correct the problem.
- The generator's frequency meter (Figure 44) should be displaying the 50 cycle output frequency in **HERTZ**.

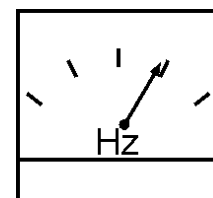

**Figure 44. Frequency Meter**

# GENERATOR START-UP PROCEDURE

6. The generator's AC-voltmeter (Figure 45) will display the generator's output in **VOLTS**..

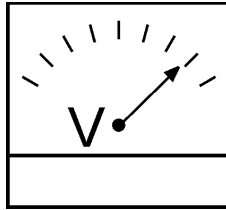

**Figure 45. Voltmeter Meter**

7. If the voltage is not within the specified tolerance use the voltage adjustment control knob (Figure 46) to increase or decrease the desired voltage.

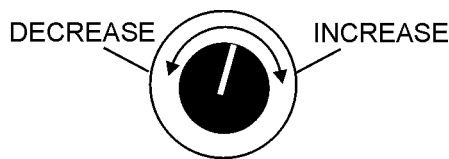

**Figure 46. Voltage Adjust Control Knob**

8. The ammeter (Figure 47) will indicate **zero amps** with no load applied. When a load is applied, the ammeter will indicate the amount of current that the load is drawing from the generator.

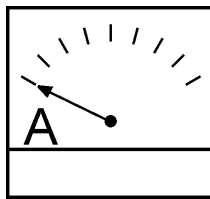

**Figure 47. Ammeter (No Load)**

9. The engine oil pressure gauge (Figure 48) will indicate the oil pressure of the engine. Under normal operating conditions the oil pressure is approximately 42 to 71 psi. (290~490 kPa).

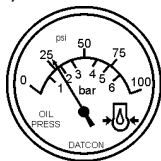

**Figure 48. Oil Pressure Gauge**

10. The **coolant temperature gauge** (Figure 49) will indicate the coolant temperature. Under normal operating conditions the coolant temperature should be between 167°~203°F (75°~95°C) (**Green Zone**).

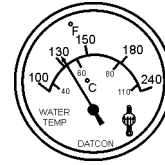

**Figure 49. Coolant Temperature Gauge**

11. The **tachometer gauge** (Figure 50) will indicate the speed of the engine when the generator is operating. Under normal operating conditions this speed is approximately 1800 RPM's.

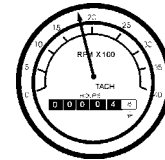

**Figure 50. Engine Tachometer Gauge**

12. Place the **main, GFCI, and aux.** circuit breakers in the **ON** position (Figure 51).

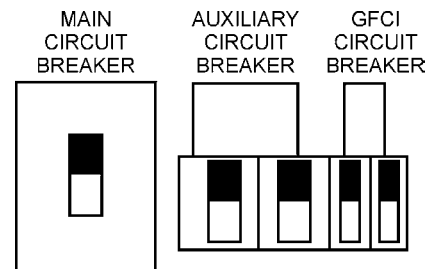

**Figure 51. Main, Aux. and GFCI Circuit Breakers (ON)**

13. Observe the generator's ammeter (Figure 52) and verify it reads the anticipated amount of current with respect to the load. The ammeter will only display a current reading if a load is in use.

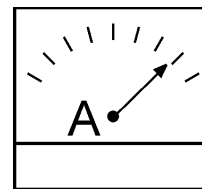

**Figure 52. Ammeter (Load)**

14. The generator will run until manually stopped or an abnormal condition occurs.

**WARNING**

**NEVER** stop the engine suddenly except in an emergency.

# GENERATOR SHUT-DOWN PROCEDURES

## NORMAL SHUTDOWN PROCEDURE

To shutdown the generator, use the following procedure:

1. Place both the **MAIN, GFCI and LOAD** circuit breakers as shown in Figure 53 to the **OFF** position.

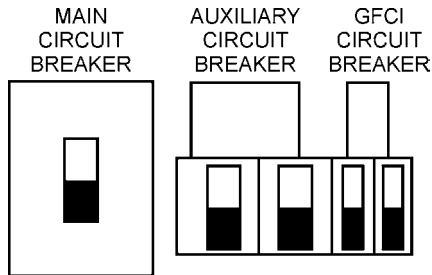

**Figure 53. Main, GFCI and Load Circuit Breakers Off**

2. Let the engine cool by running it at low speed for 3-5 minutes with no load applied.
3. Place the ignition switch (Figure 54) in the “**STOP**” position, remove the key and store in a safe place.

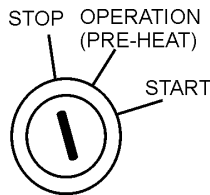
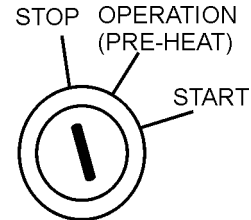

**Figure 54. Ignition (Switch Normal)**

4. Remove all loads from the generator.
5. Inspect entire generator for any damage or loosening of components that may have occurred during operation.

## EMERGENCY SHUTDOWN PROCEDURE

1. Place the **main, G.F.C.I., and aux.** circuit breakers (Figure 55) in the **OFF** position.
2. Turn the ignition key (Figure 55) to the **STOP** position.



**Figure 55. Ignition Switch (Emergency)**

Table 14. Inspection/Maintenance		10 Hrs DAILY	250 Hrs	500 Hrs	1000 Hrs
<b>Engine</b>	Check Engine Fluid Levels	X			
	Check Air Cleaner	X			
	Check Battery Acid Level	X			
	Check Fan Belt Condition	X			
	Check for Leaks	X			
	Check for Loosening of Parts	X			
	Replace Engine Oil and Filter * 1		X		
	Clean Air Filter		X		
	Check Fuel Filter/Water Separator Bowl	X			
	Clean Unit, Inside and Outside		X		
	Change Fuel Filter			X	
	Clean Radiator and Check Coolant Protection Level*2			X	
	Replace Air Filter Element * 3			X	
	Check all Hoses and Clamps * 4				X
	Clean Inside of Fuel Tank				X
<b>Generator</b>	Measure Insulation Resistance Over 3M ohms		X		
	Check Rotor Rear Support Bearing			X	

\*1 Replace engine oil and filter at 100 hours, first time only.

\*2 Add "Supplemental Coolant Additives (SCA'S)" to recharge the engine coolant.

\*3 Replace primary air filter element when restriction indicator shows a vacuum of 625 mm (25 in. H2O).

\*4 If blowby hose needs to be replaced, ensure that the slope of the blowby hose is at least a 1/2 inch per foot, with no sags or dips that could collect moisture and/or oil.

## GENERAL INSPECTION

Prior to each use, the generator should be cleaned and inspected for deficiencies. Check for loose, missing or damaged nuts, bolts or other fasteners. Also check for fuel, oil, and coolant leaks. Use Table 14 as a general maintenance guideline **Engine Side** (Refer to the Engine Instruction Manual)

### AIR CLEANER

Every 250 hours: Remove air cleaner element (Figure 56) and clean the heavy duty paper element with light spray of compressed air. Replace the air cleaner as needed.

#### Air Cleaner with Dust Indicator

This indicator (Figure 56) is attached to the air cleaner. When the air cleaner element is clogged, air intake restriction becomes greater and the dust indicator signal shows **RED** meaning the element needs changing or service. After changing the air element, press the dust indicator button to reset the indicator.

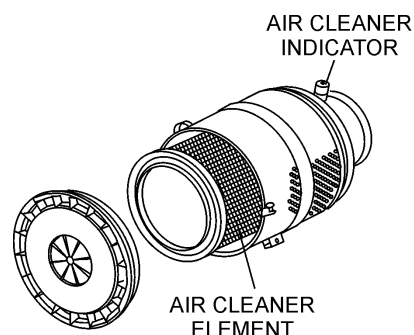

**Figure 56. Air Cleaner/Indicator**

#### NOTICE

The air filter should not be changed until the indicator reads "**RED**". Dispose of old air filter. It may not be cleaned or reused.

If the engine is operating in very **dusty** or **dry grass** conditions, a clogged air cleaner will result. This can lead to a loss of power, excessive carbon buildup in the combustion chamber and high fuel consumption. Change air cleaner more **frequently** if these conditions exist.

## FUEL ADDITION

Add diesel fuel (the grade may vary according to season and locations).

## Removing Water from the Fuel Tank

After prolonged use, water and other impurities accumulate in the bottom of the tank. Occasionally inspect the fuel tank for water contamination and drain the contents if required.

During cold weather, the more empty volume inside the tank, the easier it is for water to condense. This can be reduced by keeping the tank full with diesel fuel.

## Cleaning Inside the Fuel Tank

If necessary, drain the fuel inside the fuel tank completely. Using a spray washer (Figure 57) wash out any deposits or debris that have accumulated inside the fuel tank.

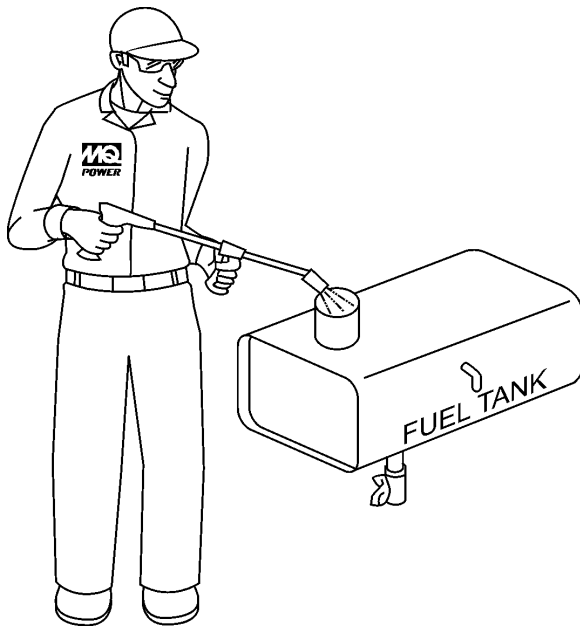

Figure 57. Fuel Tank Cleaning

## FUEL TANK INSPECTION

In addition to cleaning the fuel tank, the following components should be inspected for wear:

- **Rubber Suspension** — look for signs of wear or deformity due to contact with oil. Replace the rubber suspension if necessary.
- **Fuel Hoses** — inspect nylon and rubber hoses for signs of wear, deterioration and hardening.
- **Fuel Tank Lining** — inspect the fuel tank lining for signs of excessive amounts of oil or other foreign matter.

## Replacing Fuel Filter

- Replace the fuel filter cartridge with new one every 500 hours or so.
- Loosen the drain plug at the lower top of the fuel filter. Drain the fuel in the fuel body together with the mixed water. **DO NOT** spill the fuel during disassembly.
- Vent any air

## AIR REMOVAL

If air enters the fuel injection system of a diesel engine, starting becomes impossible. After running out of fuel, or after disassembling the fuel system, bleed the system according to the following procedure. See the **ISUZU Engine Manual** for details.

To restart after running out of fuel, turn the switch to the “ON” position for 15-30 seconds. Try again, if needed.

## CHECK OIL LEVEL

Check the crankcase oil level prior to each use, or when the fuel tank is filled. Insufficient oil may cause severe damage to the engine. Make sure the generator is level. The oil level must be between the two notches on the dipstick as shown in Figure 31.

## Replacing Oil Filter

- Remove the old oil filter.
- Apply a film of oil to the gasket on the new oil filter.
- Install the new oil filter.
- After the oil cartridge has been replaced, the engine oil will drop slightly. Run the engine for a while and check for leaks before adding more oil if needed. Clean excessive oil from engine.

## FLUSHING OUT RADIATOR AND REPLACING COOLANT

- Open both cocks located at the crankcase side and at the lower part of the radiator and drain coolant. Open the radiator cap while draining. Remove the overflow tank and drain.
- Check hoses for softening and kinks. Check clamps for signs of leakage.
- Tighten both cocks and replace the overflow tank.
- Replace with coolant as recommended by the engine manufacturer.
- Close radiator cap tightly.
- Flush the radiator by running clean tap water through radiator until signs of rust and dirt are removed. **DO NOT** clean radiator core with any objects, such as a screwdriver.

### WARNING



Allow engine to **cool** when flushing out radiator. Flushing the radiator while hot could cause serious burns from water or steam.

## RADIATOR CLEANING

The radiator (Figure 58) should be sprayed (cleaned) with a high pressure washer when excessive amounts of dirt and debris have accumulated on the cooling fins or tube. When using a high pressure washer, stand at least 5 feet (1.5 meters) away from the radiator to prevent damage to the fins and tube.

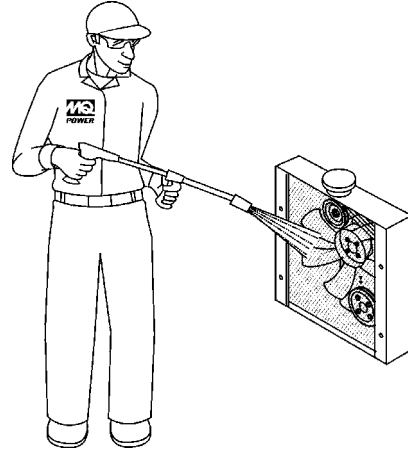

Figure 58. Radiator Cleaning

## GENERATOR STORAGE

For long term storage of the generator the following is recommended:

- Drain the fuel tank completely. Treat with a fuel stabilizer if necessary.
- Completely drain the oil from the crankcase and refill if necessary with fresh oil.
- Clean the entire generator, internal and external.
- Cover the generating set and store in a clean, dry place.
- Disconnect the battery.
- Make sure engine coolant is at proper level.
- If generator is mounted on a trailer, jack trailer up and place on blocks so tires do not touch the ground or block and completely remove the tires.

# TRAILER MAINTENANCE

The following trailer maintenance guidelines are intended to assist the operator in preventive maintenance.

## TRAILER BRAKES

Properly functioning brake shoes and drums are essential to ensure safety. The brakes should be inspected the first 200 miles of operation. This will allow the brake shoes and drums to seat properly. After the first 200 mile interval, inspect the brakes every 3,000 miles. If driving over rough terrain, inspect the brakes more frequently.

## HYDRAULIC BRAKES

If your trailer has hydraulic brakes, they function the same way the surge brakes do on your tow vehicle. The hydraulic braking system must be inspected at least as often as the brakes on the tow vehicle, but no less than once per year. This inspection includes an assessment of the condition and proper operation of the wheel cylinders, brake shoes, brake drums and hubs.

## MANUALLY ADJUSTING THE BRAKES

Most axles are fitted with a brake mechanism that will adjust the brakes during a hard stop. However, some braking systems are not automatically adjusted by hard stopping. These brakes require manual adjustment. The following steps apply to adjust most manually adjustable brakes.

1. Jack up the trailer and secure it on adequate capacity jackstands.
2. Be sure the wheel and brake drum rotate freely.
3. Remove the adjusting-hole cover from the adjusting slot on the bottom of the brake backing plate.
4. With a screwdriver or standard adjusting tool, rotate the starwheel of the adjuster assembly to expand the brake shoes. Adjust the brake shoes out until the pressure of the linings against the drum makes the wheel very difficult to turn. Note: Your trailer maybe equipped with drop spindle axles. See axle manual for your axle type. You will need a modified adjusting tool for adjusting the brakes in these axles. With drop spindle axles, a modified adjusting tool with about an 80 degree angle should be used.
5. Rotate the starwheel in the opposite direction until the wheel turns freely with a slight drag.

6. Replace the adjusting-hole cover.
7. Repeat the above procedure on all brakes.
8. Lower the trailer to the ground.

Check the fluid level in the master cylinder reservoir at least every three months. If you tow your trailer an average of 1,000 miles per month in a hot and dry environment, you must check the brake fluid level once a month. The brake fluid reservoir is located on the tongue of the trailer. Always fill with clean, uncontaminated DOT 4 brake fluid.

Figure 59 below displays the major hydraulic brake components that will require inspection and maintenance. Please inspect these components as required using steps 1 through 6 as referenced in the “Manually Adjusting The Brakes” section on this page. See Table 1 for Hydraulic Brake Troubleshooting.

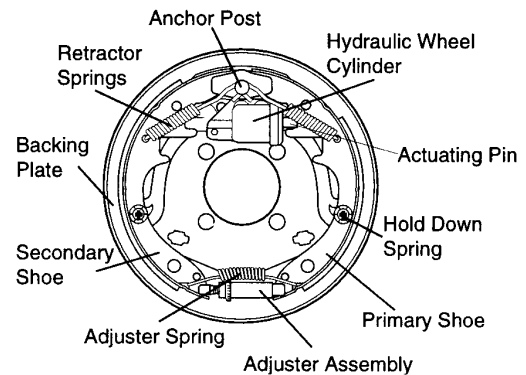

Figure 59. Hydraulic Brake Components

## HYDRAULIC BRAKE ACTUATOR

The hydraulic brake actuator (Figure 60) is the mechanism that activates the trailer’s brake system. This actuator changes fluid power into mechanical power. Therefore, the fluid level must be checked frequently to assure that the brakes function properly.

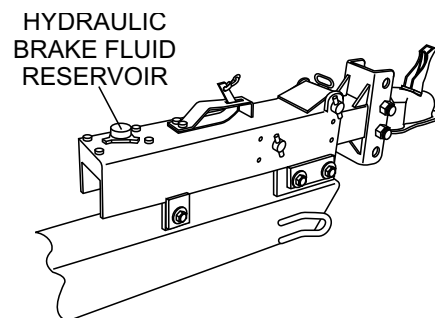

Figure 60. Hydraulic Brake Actuator

# TRAILER MAINTENANCE

## WARNING

Failure to maintain proper fluid level in the actuator may result in loss of braking action which could cause severe property damage, injury or death.

Periodically check the actuator mounting fasteners for damage or loosening. Inspect the actuator for worn or damaged parts. As you are towing your trailer, be aware of any changes in braking quality. This could be an early warning of brake or actuator malfunction and requires immediate attention. Consult a certified brake specialist to make necessary adjustment or repairs.

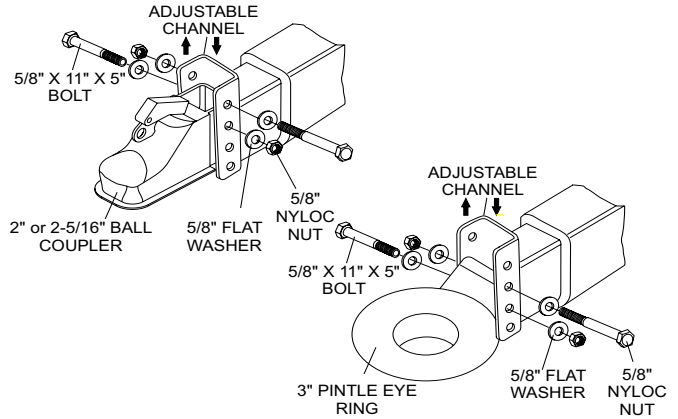

Figure 61. Adjustable Channel

Table 15. Hydraulic Brake Troubleshooting

Symptom	Possible Cause	Solution
No Brakes	Brake line broken or kinked?	Repair or replace.
Weak Brakes or Brakes Pull to One Side	Brake lining glazed?	Reburnish or replace.
	Trailer overloaded?	Correct weight.
	Brake drums scored or grooved?	Machine or replace.
	Tire pressure correct?	Inflate all tires equally.
	Tires unmatched on the same axle?	Match tires.
Locking Brakes	Brake components loose, bent or broken?	Replace components.
	Brake drums out-of-round?	Replace.
Noisy Brakes	System lubricated?	Lubricate.
	Brake components correct?	Replace and correct.
Dragging Brakes	Brake lining thickness incorrect or not adjusted correctly?	Install new shoes and linings.
	Enough brake fluid or correct fluid?	Replace rubber parts fill with dot 4 fluid.

## ADJUSTABLE CHANNEL

Your trailer may be equipped with an adjustable channel (Figure 61) that allows the coupler to be raised or lowered to a desired height. Periodically check the channel bolts for damage or loosening.

## NOTICE

When replacing channel mounting hardware (nuts, bolts and washers), **NEVER** substitute substandard hardware. Pay close attention to **bolt length** and **grade**. **ALWAYS** use manufacturer's recommended parts when replacing channel mounting hardware.

## Wheel Bearings

Wheel bearings (Figure 62) must be inspected and lubricated once a year or 12,000 miles to insure safe operation of your trailer.

If trailer wheel bearings are immersed in water, they must be replaced.

## DANGER

If trailer wheels are under water for a long period of time, wheel bearings may fail. If this is the case, service wheel bearings immediately.

The possibility exists of the wheels falling off causing equipment damage and severe bodily harm even death!

If the trailer has not been used for an extended amount of time, have the bearings inspected and packed more frequently, at least every six months and prior to use.

Follow the steps below to disassemble the wheel hub and service the wheel bearings. See Figure 62.

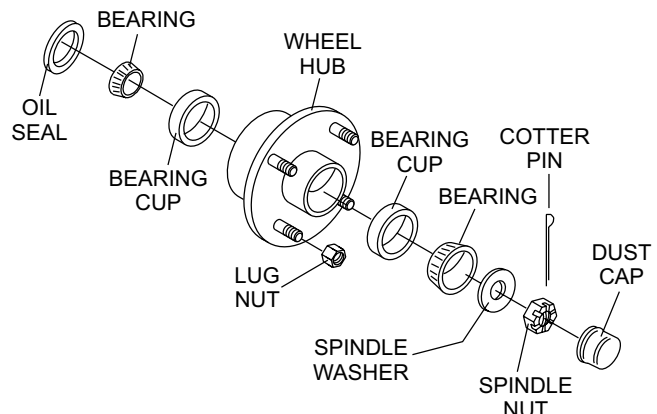

Figure 62. Wheel Hub Components



# TRAILER MAINTENANCE

- After removing the dust cap, cotter pin, spindle nut and spindle washer, remove the hub to inspect the bearings for wear and damage.
- Replace bearings that have flat spots on rollers, broken roller cages, rust or pitting. Always replace bearings and cups in sets. The inner and outer bearings are to be replaced at the same time.
- Replace seals that have nicks, tears or wear.
- Lubricate the bearings with a high quality EP-2 automotive wheel bearing grease.

## WHEEL HUB ADJUSTMENT

Every time the wheel hub is removed and the bearings are reassembled, follow the steps below to check the wheel bearings for free running and adjust.

- Turn the hub slowly, by hand, while tightening the spindle nut until you can no longer turn the hub by hand.
- Loosen the spindle nut just until you are able to turn it (the spindle nut) by hand. Do not turn the hub while the spindle nut is loose.
- Install a new cotter pin through the spindle nut and axle.
- Check the adjustments. Both the hub and the spindle nut should be able to move freely (the spindle nut motion will be limited by the cotter pin).

### **!** DANGER

**NEVER** crawl under the trailer unless it is on firm and level ground and resting on properly placed and secured jackstands.

The possibility exists of the trailer falling thus causing equipment damage and severe bodily harm even death!

### **!** DANGER

When performing trailer inspection and maintenance activities, you must jack up the trailer using jacks and jackstands.

When jacking and using jackstands, place them so as to clear wiring, brake lines, and suspension parts (i.e., springs, torsion bars). Place jacks and jackstands inside of the perimeter strip on the supporting structure to which the axles are attached.

### **!** DANGER

Improper weld repair will lead to early failure of the trailer structure and can cause serious injury or death.

**DO NOT** repair cracked or broken welds unless you have a certified welder perform the repair. If not, have the welds repaired by your dealer.

### **!** WARNING

If the trailer is involved in an accident, have it inspected immediately by qualified personnel. In addition, the trailer should be inspected annually for signs of wear or deformations.

## LEAF SUSPENSION

The leaf suspension springs and associated components (Figure 63) should be visually inspected every 6,000 miles for signs of excessive wear, elongation of bolt holes, and loosening of fasteners. Replace all damaged parts (suspension) immediately

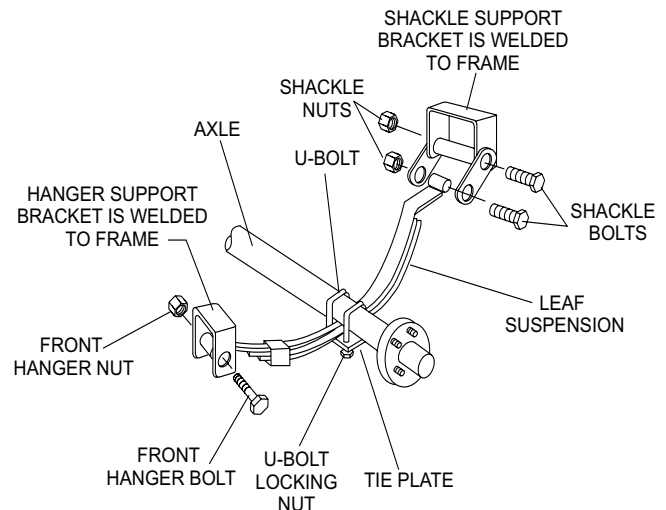

Figure 63. Leaf Suspension Components

### **!** DANGER

Worn or broken suspension parts can cause loss of control, damage to equipment and severe bodily injury, even death!

Check suspension regularly.

# TRAILER MAINTENANCE

Torque suspension components (Figure 63) as referenced in Table 16.

Item	Torque (Ft.-Lbs.)
3/8" U-Bolt	Min-30 Max-35
7/16" U-Bolt	Min-45 Max-60
1/2" U-Bolt	Min-45 Max-60
Shackle Bolt Spring Eye Bolt	Snug fit only. Parts must rotate freely. Locking nuts or cotter pins are provided to retain nut-bolt assembly.
Shoulder Type Shackle Bolt	Min-30 Max-50

## TIRES/WHEELS/LUG NUTS

Tires and wheels are a very important and critical components of the trailer. When specifying or replacing the trailer wheels it is important the wheels, tires, and axle are properly matched.

**⚠ CAUTION**



**ALWAYS** wear safety glasses when removing or installing force fitted parts. Failure to comply may result in serious injury.

**⚠ CAUTION**









**DO NOT** attempt to repair or modify a wheel. **DO NOT** install in inner tube to correct a leak through the rim. If the rim is cracked, the air pressure in the inner tube may cause pieces of the rim to explode (break off) with great force and cause serious eye or bodily injury.

### Tire Wear/Inflation

Tire inflation pressure is the most important factor in tire life. Pressure should be checked cold before operation **DO NOT** bleed air from tires when they are **hot!**. Check inflation pressure weekly during use to insure the maximum tire life and tread wear.

Table 17 (Tire Wear Troubleshooting) will help pinpoint the causes and solutions of tire wear problems.

Wear Pattern	Cause	Solution
 Center Wear	Over inflation.	Adjust pressure to particular load per tire manufacturer.
 Edge Wear	Under inflation.	Adjust pressure to particular load per tire manufacturer.
 Side Wear	Loss of camber or overloading.	Make sure load does not exceed axle rating. Align wheels.
 Toe Wear	Incorrect toe-in.	Align wheels.
 Cupping	Out-of-balance.	Check bearing adjustment and balance tires.
 Flat Spots	Wheel lockup and tire skidding.	Avoid sudden stops when possible and adjust brakes.

### Lug Nut Torque Requirements

It is extremely important to apply and maintain proper wheel mounting torque on the trailer. Be sure to use only the fasteners matched to the cone angle of the wheel. Proper procedure for attachment of the wheels is as follows:

1. Start all wheel lug nuts by hand.
2. Torque all lug nuts in sequence (see Figure 64). **DO NOT** torque the wheel lug nuts all the way down. Tighten each lug nut in 3 separate passes as defined by Table 18.
3. After first road use, retorque all lug nuts in sequence. Check all wheel lug nuts periodically

Wheel Size	First Pass FT-LBS	Second Pass FT-LBS	Third Pass FT-LBS
12"	20-25	35-40	50-65
13"	20-25	35-40	50-65
14"	20-25	50-60	90-120
15"	20-25	50-60	90-120
16"	20-25	50-60	90-120

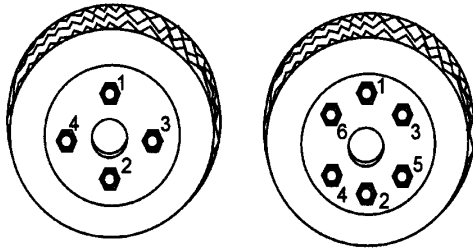

4-LUG NUTS

6-LUG NUTS

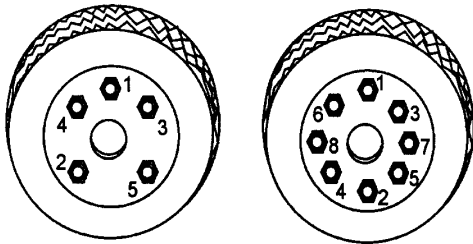

5-LUG NUTS

8-LUG NUTS

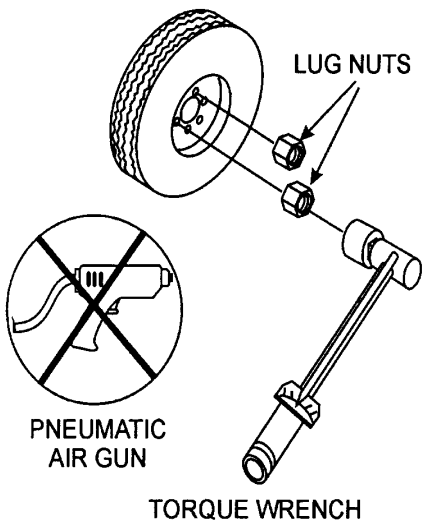

**Figure 64. Wheel Lug Nuts Tightening Sequenc**

**NOTICE**

**NEVER** use an pneumatic air gun to tighten wheel lug nuts.

# TRAILER WIRING DIAGRAM

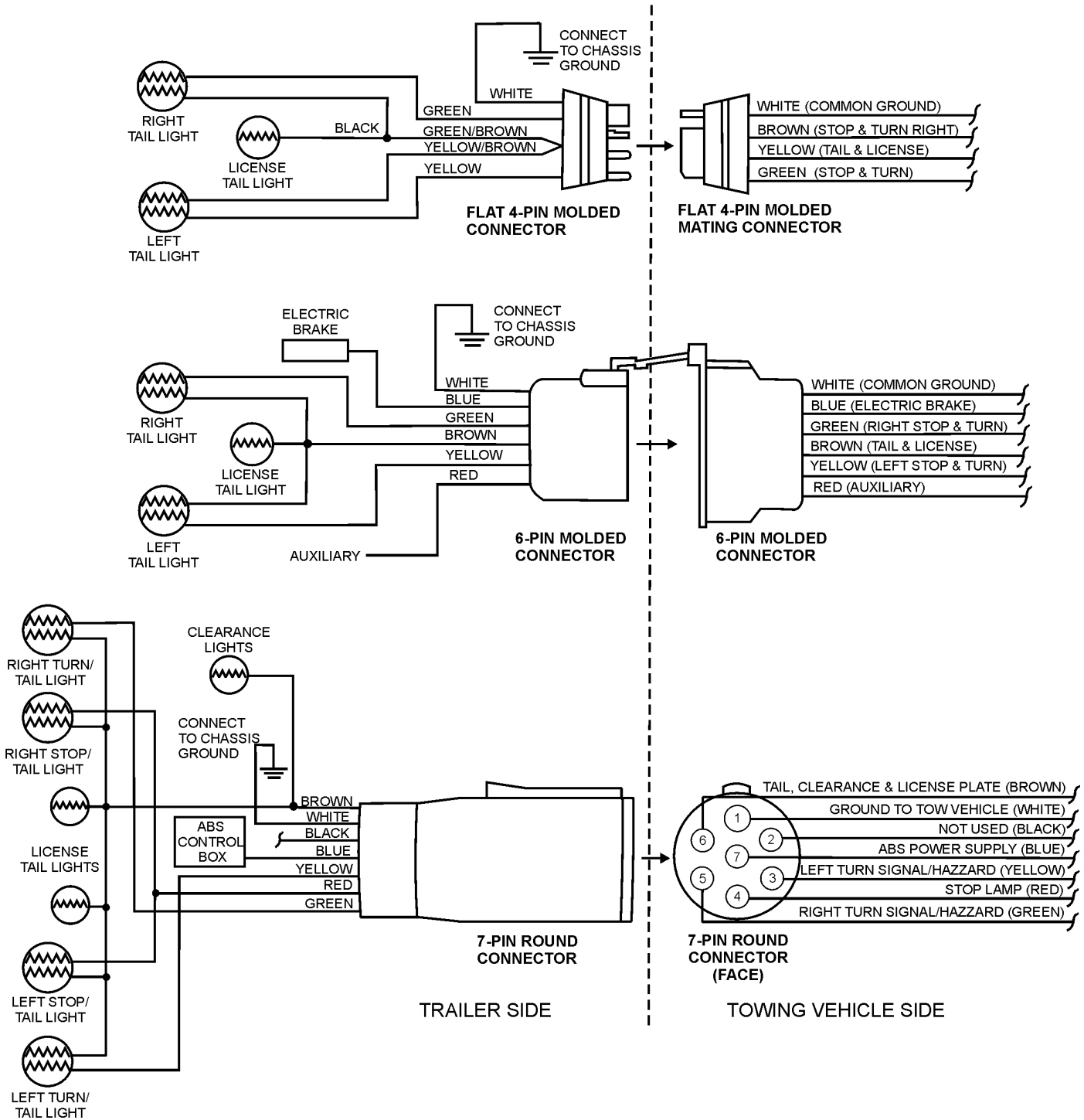
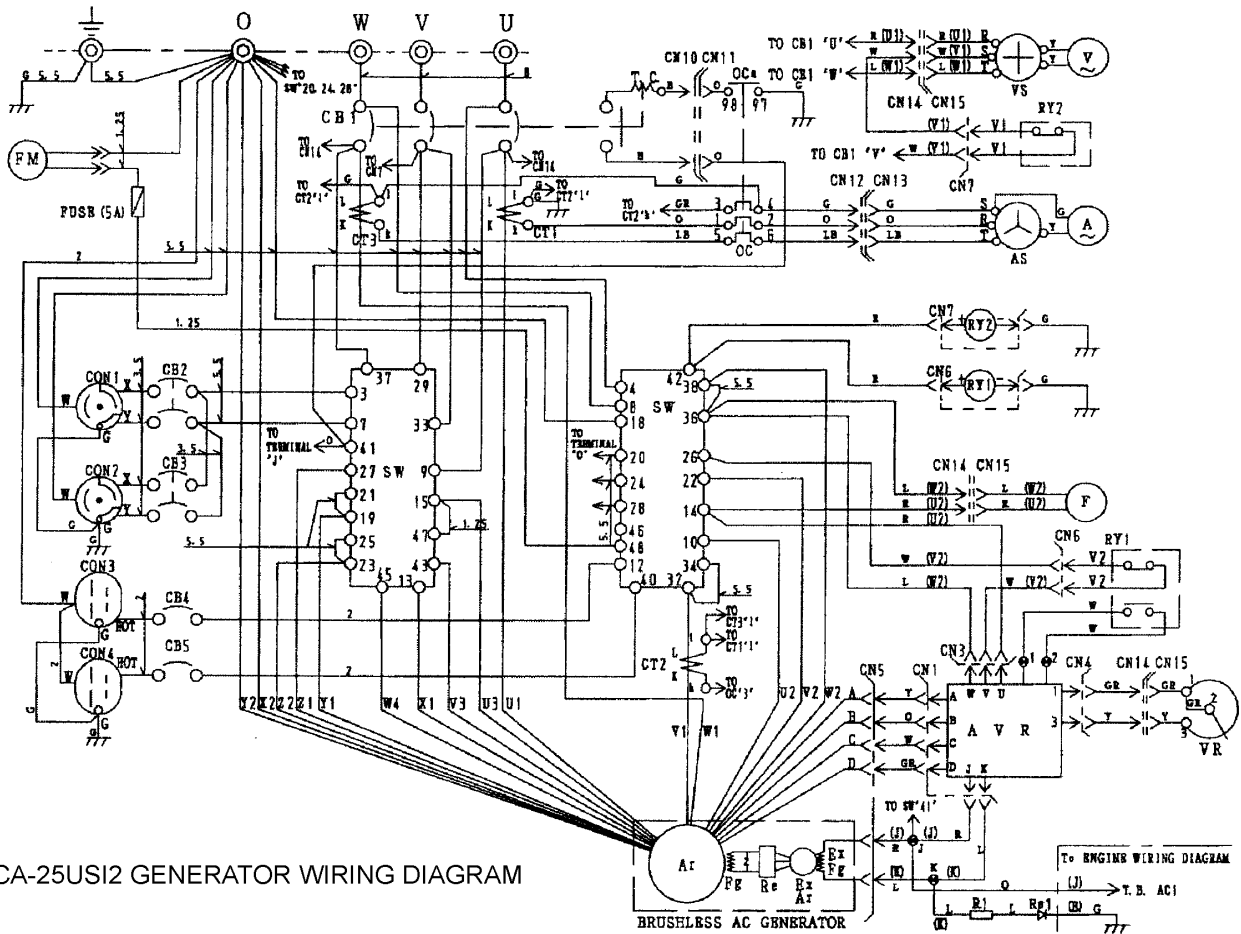

Figure 65. Trailer/Towing Vehicle Wiring Diagram

# GENERATOR WIRING DIAGRAM



DCA-25USI2 GENERATOR WIRING DIAGRAM

### CONNECTOR ARRANGEMENT (WIRING VIEW)

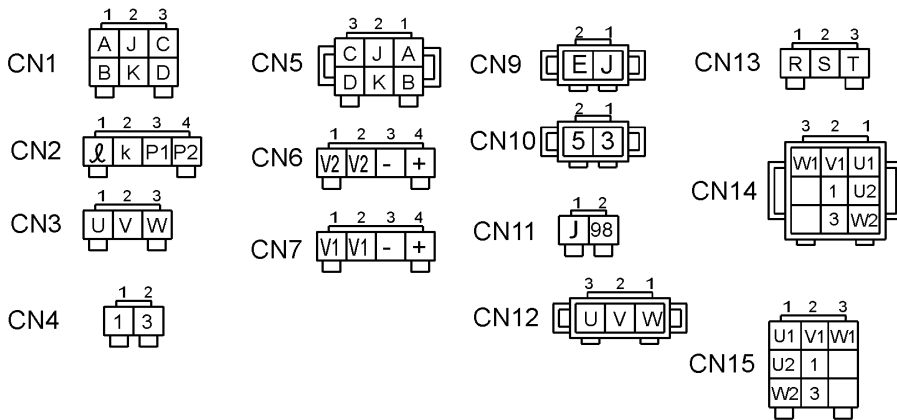

### COLOR CODE

SYM.	WIRE COLOR	SYM.	WIRE COLOR
B	BLACK	R	RED
L	BLUE	W	WHITE
BR	BROWN	Y	YELLOW
G	GREEN	LB	LIGHT BLUE
GR	GRAY	LG	LIGHT GREEN
V	VIOLET	O	ORANGE
P	PINK		

### Notice:

1. No designation lead size : 1.25

SYMBOL	DESIGNATION
Ar	MAIN GENERATOR ARMATURE WINDING
Fg	MAIN GENERATOR FIELD WINDING
ExAr	EXCITER ARMATURE WINDING
ExFg	EXCITER FIELD WINDING
Re	RECTIFIER
AVR	AUTOMATIC VOLTAGE REGULATOR
VR	VOLTAGE REGULATOR (RHEOSTAT)
CT 1,2,3	CURRENT TRANSFORMER
AS	CHANGE-OVER SWITCH AMMETER
A	AC AMMETER
VS	CHANGE-OVER SWITCH, VOLTMETER
V	AC VOLTMETER
F	FREQUENCY METER
CB1	CIRCUIT BREAKER 3P 60A
CB2,3	CIRCUIT BREAKER 2P 50A
CB4,5	CIRCUIT BREAKER 1P 20A
CN1,2	RECEPTACLE 250V 50A
CN3,4	RECEPTACLE 125V 20AX2
OC	OVER CURRENT RELAY
SW	SELECTOR SWITCH
RY1,2	RELAY UNIT
Re1	RELAY RECTIFIER
FM	FAN MOTOR
FUSE	5 AMPS
	TERMINAL

Figure 66. Generator Wiring Diagram

# 600 VAC AUTO TRANSFORMER WIRING DIAGRAM

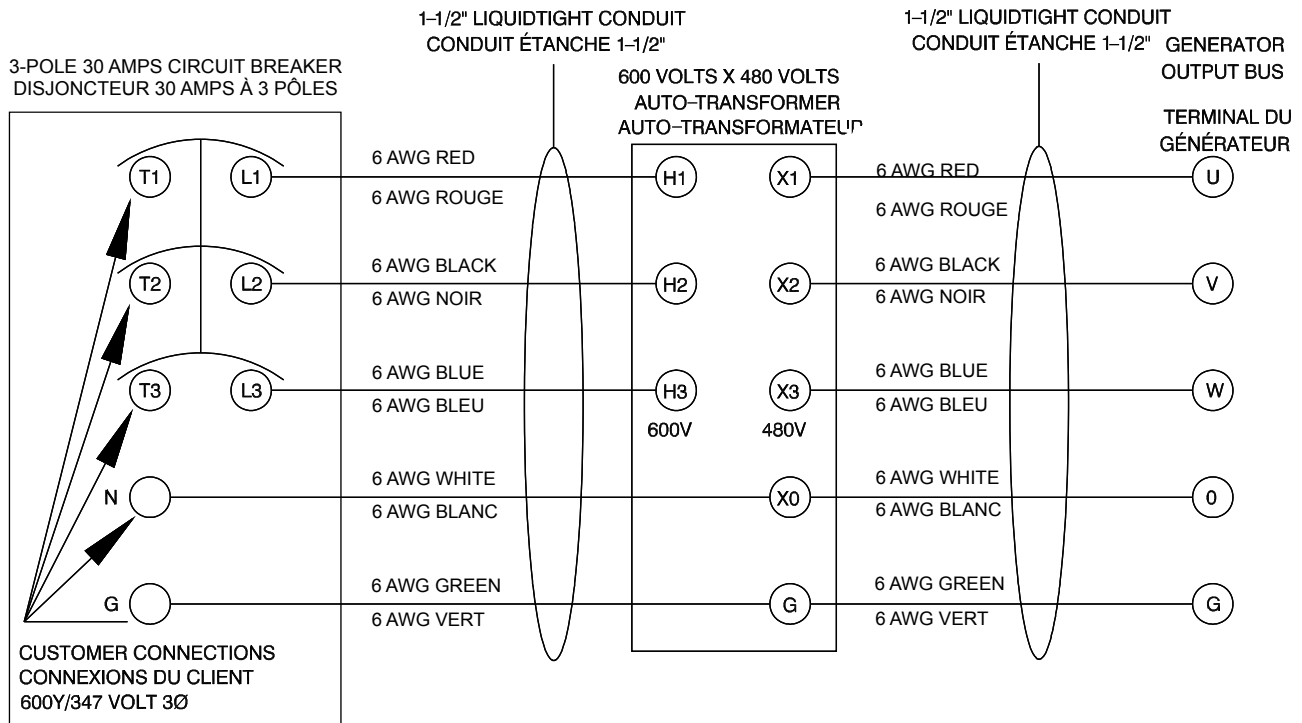
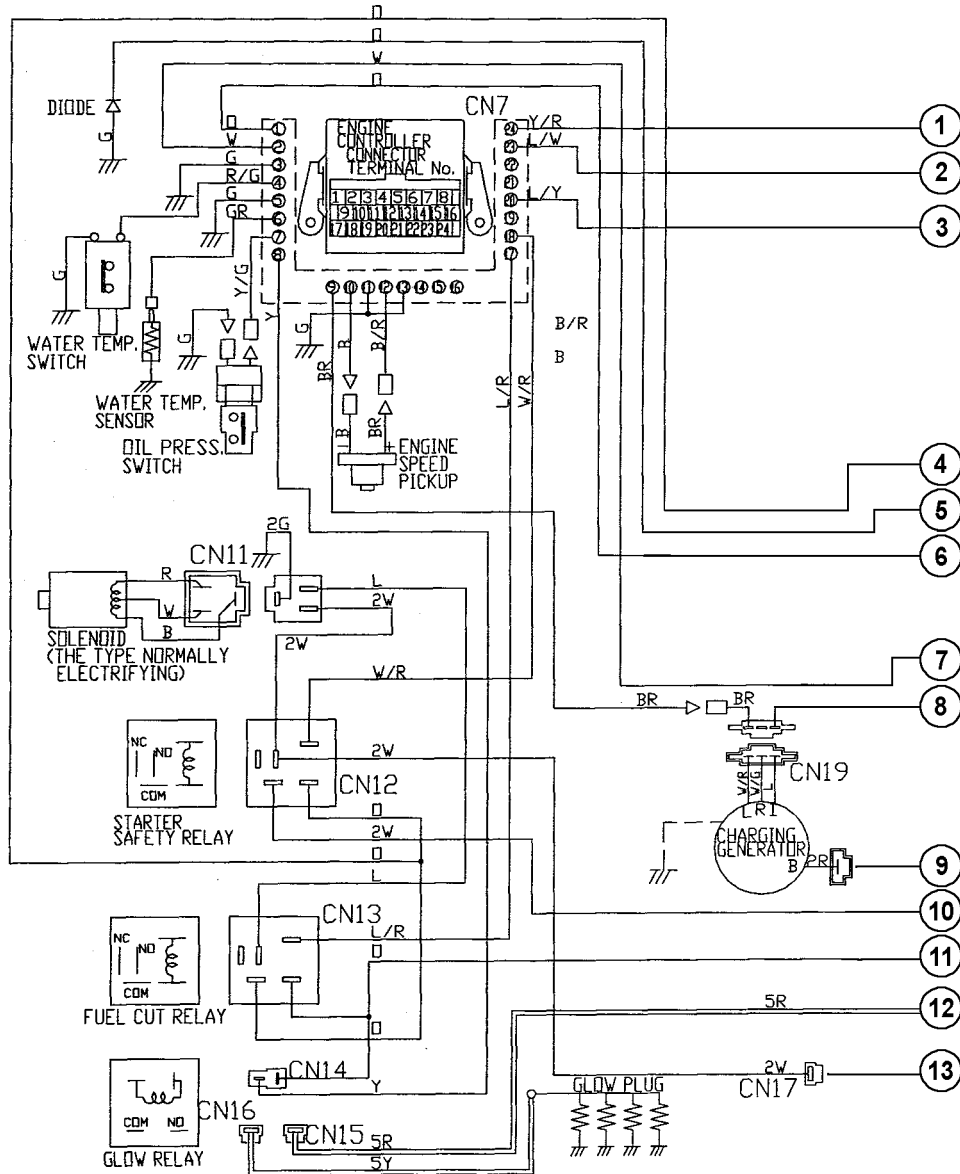

Figure 67. 600 VAC Auto Transformer Wiring Diagram



# ENGINE WIRING DIAGRAM



COLOR CODE			
SYM.	WIRE COLOR	SYM.	WIRE COLOR
B	BLACK	R	RED
L	BLUE	W	WHITE
BR	BROWN	Y	YELLOW
G	GREEN	LB	LIGHT BLUE
GR	GRAY	LG	LIGHT GREEN
V	VIOLET	O	ORANGE
P	PINK		

CONNECTOR  
(VIEW FROM INSERTING WIRE SIDE)

KEY CONNECTION DIAGRAM						
	B	Br	R1	ACC	R2	C
OFF	○					
RUN	○	○		○		
START	○	○		○	○	○

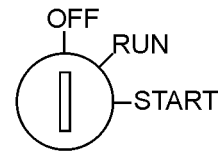
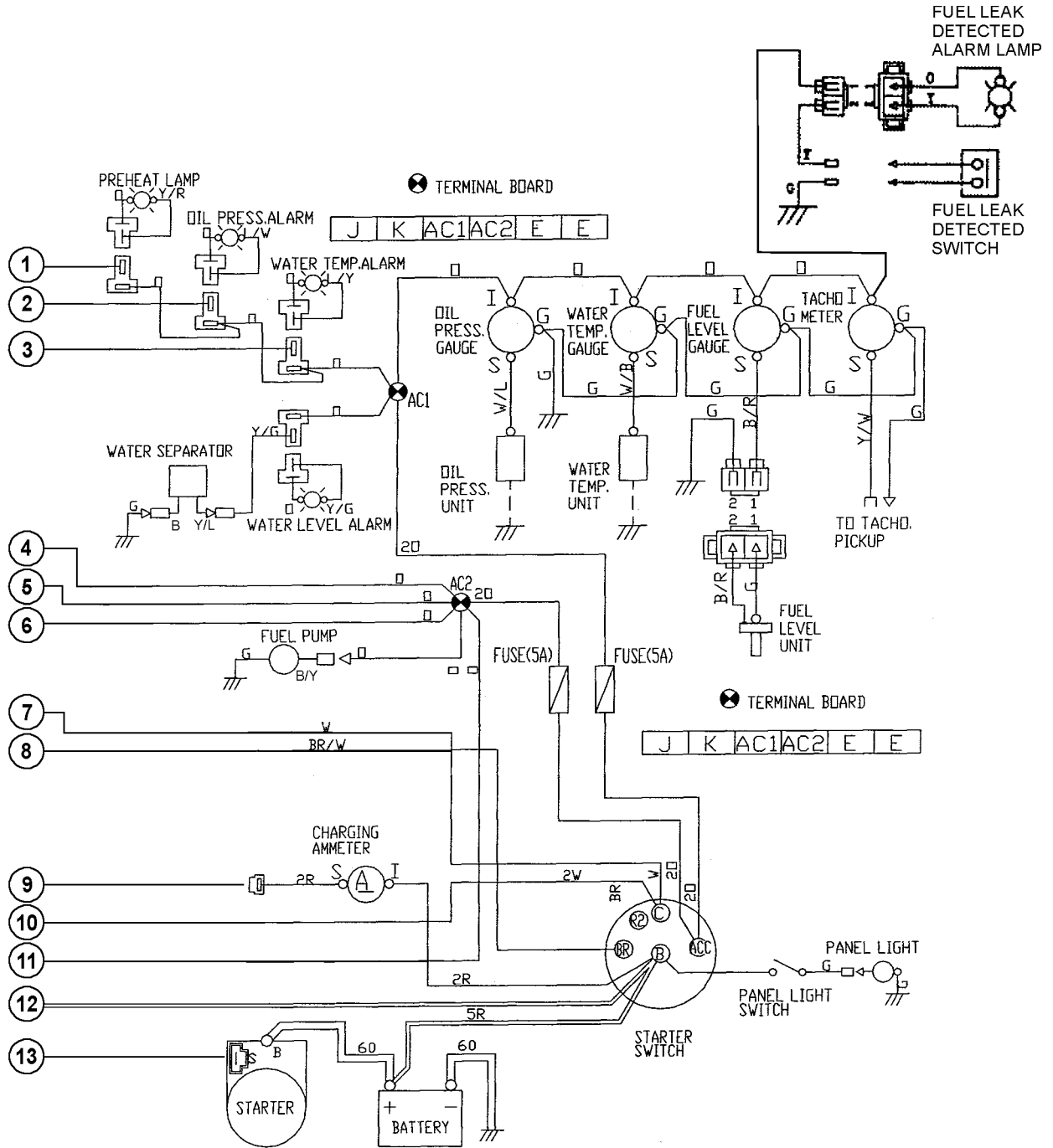

Figure 68. Engine Wiring Diagram



# ENGINE WIRING DIAGRAM



← CONTINUED FROM PREVIOUS PAGE

## TROUBLESHOOTING (GENERATOR)

Practically all breakdowns can be prevented by proper handling and maintenance inspections, but in the event of a breakdown, use Table 17 shown below for diagnosis of the Generator. If the problem cannot be remedied, consult our company's business office or service plant.

**Table 19. Generator Troubleshooting**

Symptom	Possible Problem	Solution
No Voltage Output	AC Voltmeter defective?	Check output voltage using a voltmeter.
	Is wiring connection loose?	Check wiring and repair.
	Is AVR defective?	Replace if necessary.
	Defective Rotating Rectifier?	Check and replace.
	Defective Exciter Field?	Check for approximately 17.3 ohms across J & K on CN1
Low Voltage Output	Is engine speed correct?	Turn engine throttle lever to "High".
	Is wiring connections loose?	Check wiring and repair.
	Defective AVR?	Replace if necessary.
High Voltage Output	Is wiring connections loose?	Check wiring and repair.
	Defective AVR?	Replace if necessary.
Circuit Breaker Tripped	Short Circuit in load?	Check load and repair.
	Over current?	Confirm load requirements and reduce.
	Defective circuit breaker?	Check and replace.
	Over current Relay actuated?	Confirm load requirement and replace.



# EXPLANATION OF CODE IN REMARKS COLUMN

The following section explains the different symbols and remarks used in the Parts section of this manual. Use the help numbers found on the back page of the manual if there are any questions.

## NOTICE

The contents and part numbers listed in the parts section are subject to change **without notice**. Multiquip does not guarantee the availability of the parts listed.

## SAMPLE PARTS LIST

NO.	PART NO.	PART NAME	QTY.	REMARKS
1	12345	BOLT.....	1	INCLUDES ITEMS W/%
2%		WASHER, 1/4 IN.....		NOT SOLD SEPARATELY
2%	12347	WASHER, 3/8 IN....	1	MQ-45T ONLY
3	12348	HOSE .....		A/R ...MAKE LOCALLY
4	12349	BEARING .....	1	S/N 2345B AND ABOVE

## NO. Column

**Unique Symbols** — All items with same unique symbol

(@, #, +, %, or >) in the number column belong to the same assembly or kit, which is indicated by a note in the “Remarks” column.

**Duplicate Item Numbers** — Duplicate numbers indicate multiple part numbers, which are in effect for the same general item, such as different size saw blade guards in use or a part that has been updated on newer versions of the same machine.

## NOTICE

When ordering a part that has more than one item number listed, check the remarks column for help in determining the proper part to order.

## PART NO. Column

**Numbers Used** — Part numbers can be indicated by a number, a blank entry, or TBD.

TBD (To Be Determined) is generally used to show a part that has not been assigned a formal part number at the time of publication.

A blank entry generally indicates that the item is not sold separately or is not sold by Multiquip. Other entries will be clarified in the “Remarks” Column.

## QTY. Column

**Numbers Used** — Item quantity can be indicated by a number, a blank entry, or A/R.

A/R (As Required) is generally used for hoses or other parts that are sold in bulk and cut to length.

A blank entry generally indicates that the item is not sold separately. Other entries will be clarified in the “Remarks” Column.

## REMARKS Column

Some of the most common notes found in the “Remarks” Column are listed below. Other additional notes needed to describe the item can also be shown.

**Assembly/Kit** — All items on the parts list with the same unique symbol will be included when this item is purchased.

Indicated by:

“INCLUDES ITEMS W/(unique symbol)”

**Serial Number Break** — Used to list an effective serial number range where a particular part is used.

Indicated by:

“S/N XXXXX AND BELOW”

“S/N XXXX AND ABOVE”

“S/N XXXX TO S/N XXX”

**Specific Model Number Use** — Indicates that the part is used only with the specific model number or model number variant listed. It can also be used to show a part is NOT used on a specific model or model number variant.

Indicated by:

“XXXXX ONLY”

“NOT USED ON XXXX”

**“Make/Obtain Locally”** — Indicates that the part can be purchased at any hardware shop or made out of available items. Examples include battery cables, shims, and certain washers and nuts.

**“Not Sold Separately”** — Indicates that an item cannot be purchased as a separate item and is either part of an assembly/kit that can be purchased, or is not available for sale through Multiquip.

## SUGGESTED SPARE PARTS

### DCA25USI4CAN WHISPERWATT GENERATOR WITH ISUZU BV-4LE2-NYGD02 DIESEL ENGINE

#### 1 to 3 units

Qty.	P/N	Description
5.....	2944566410.....	ELEMENT, OIL FILTER
5.....	8980374810.....	ELEMENT, FUEL FILTER W/O SENSOR
3.....	8944370220.....	REPAIR KIT FUEL PUMP
3.....	0602046611.....	ELEMENT, AIR
1.....	8972309390.....	BELT, FAN
1.....	M1312500203.....	RADIATOR HOSE, UPPER
1.....	M1312500303.....	RADIATOR HOSE, LOWER
1.....	8970633010.....	SENSOR, WATER TEMP. (ENGINE SIDE)
1.....	8973022030.....	SWITCH, WARNING, OVERHEAT (ENGINE SIDE)
1.....	1824100990.....	SENSOR, OIL PRESSURE (ENGINE SIDE)
1.....	0602123275.....	UNIT, WATER TEMP.
1.....	0602122272.....	UNIT, OIL PRESSURE
1.....	0601808803.....	CIRCUIT BREAKER, 1P, 20 AMP
1.....	0601808804.....	CIRCUIT BREAKER, 2P, 50 AMP
1.....	0601820602.....	AUTOMATIC VOLTAGE REGULATOR
1.....	0601810245.....	BULB, ALARM LAMP/PREHEAT LAMP
2.....	8944024980.....	KEY, IGNITION

#### NOTICE

Part number on this Suggested Spare Parts list may supersede/replace the P/N shown in the text pages of this book.

# GENERATOR ASSY.

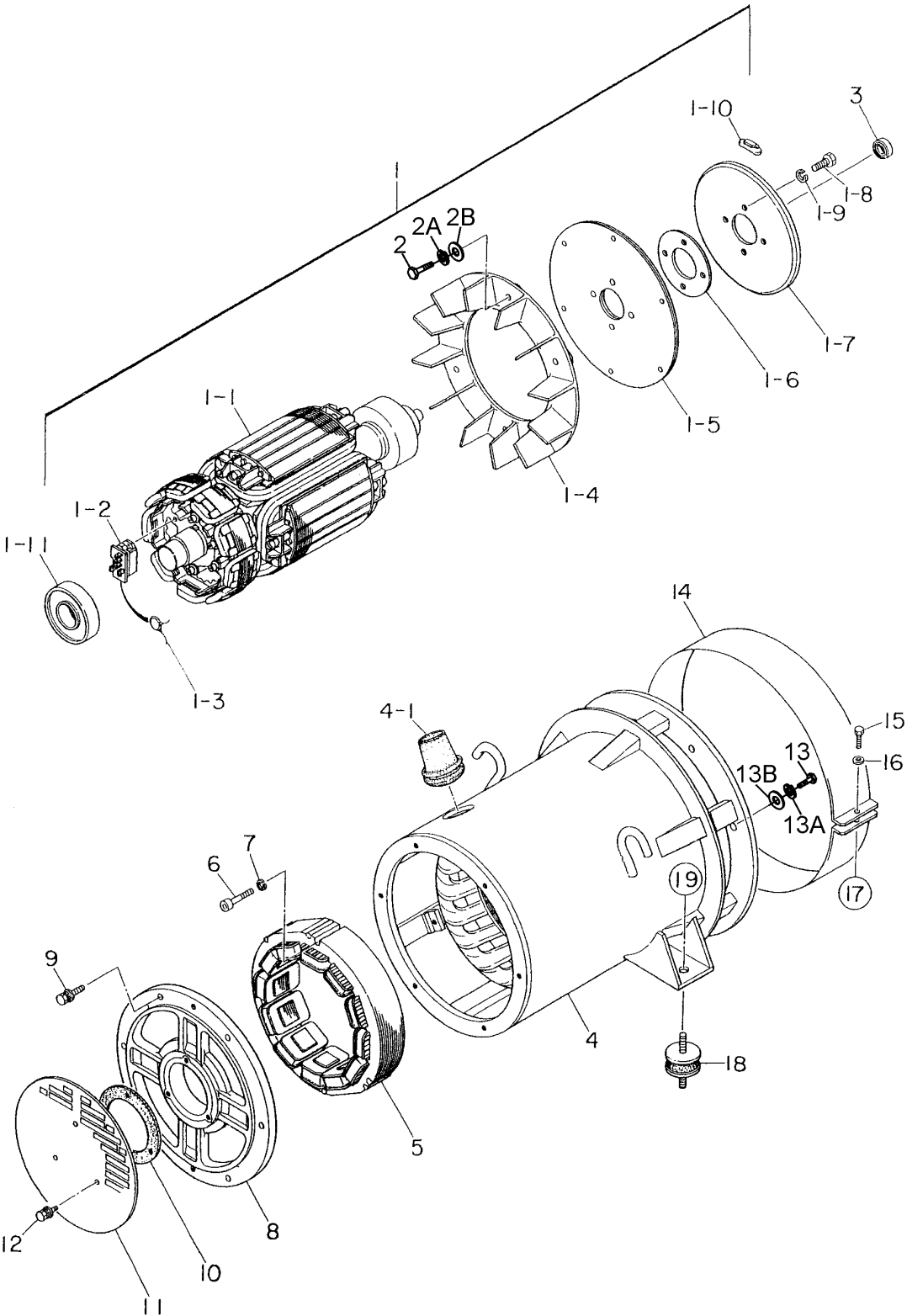

## GENERATOR ASSY.

<u>NO.</u>	<u>PART NO.</u>	<u>PART NAME</u>	<u>QTY.</u>	<u>REMARKS</u>
1	B1110200602	ROTOR ASSY.....	1.....	INCLUDES ITEMS W/\$
1-1\$		FIELD ASSY	1	
1-2\$	7961025004	RECTIFIER	1	
1-3\$	0601822630	SURGE ABSORBER	1	
1-4\$	8001070003	FAN	1	
1-5\$	8351611004	COUPLING DISK	2	
1-6\$	8351612004	WASHER, COUPLING HUB	1	
1-7\$	B1112300003	BALANCING PLATE .....	1.....	ITEM 1-10 MUST BE ORDERED WHEN REPLACING THE BALANCING PLATE
1-8\$	0010310025	HEX HEAD BOLT	4	
1-9\$	0042510000	WASHER, LOCK	4	
1-10\$	0601000209	BALANCING WEIGHT KIT	1	
1-11\$	0071906308	BEARING	1	
2	0010308035	HEX HEAD BOLT	6	
2A	0040008000	WASHER, LOCK	6	
2B	0041208000	WASHER, FLAT	6	
3	0070506803	BEARING	1	
4	B1130202103	STATOR ASSY	1	
4-1	0845041904	GROMMET	1	
5	B1138000003	FIELD ASSY, EXCITER	1	
6	0016008045	HEX SOCKET HD CAP SCREW	1	
7	0042508000	WASHER, LOCK	3	
8	8351315003	END BRACKET	1	
9	0017108035	HEX HEAD BOLT	6	
10	8351312004	PACKING	1	
11	8351331004	COVER, SUCTION	1	
12	0017106016	HEX HEAD BOLT	3	
13	0010310030	HEX HEAD BOLT	6	
13A	0040010000	WASHER, LOCK	6	
13B	0041210000	WASHER, FLAT	6	
14	B0155400204	COVER, FAN	1	
15	0010106030	HEX HEAD BOLT	1	
16	0041206000	WASHER, FLAT	1	
17	0600815000	NUT	1	
18	M9312600004	RUBBER SUSPENSION	2	
19	0207010000	HEX NUT	2	

# CONTROL BOX ASSY.

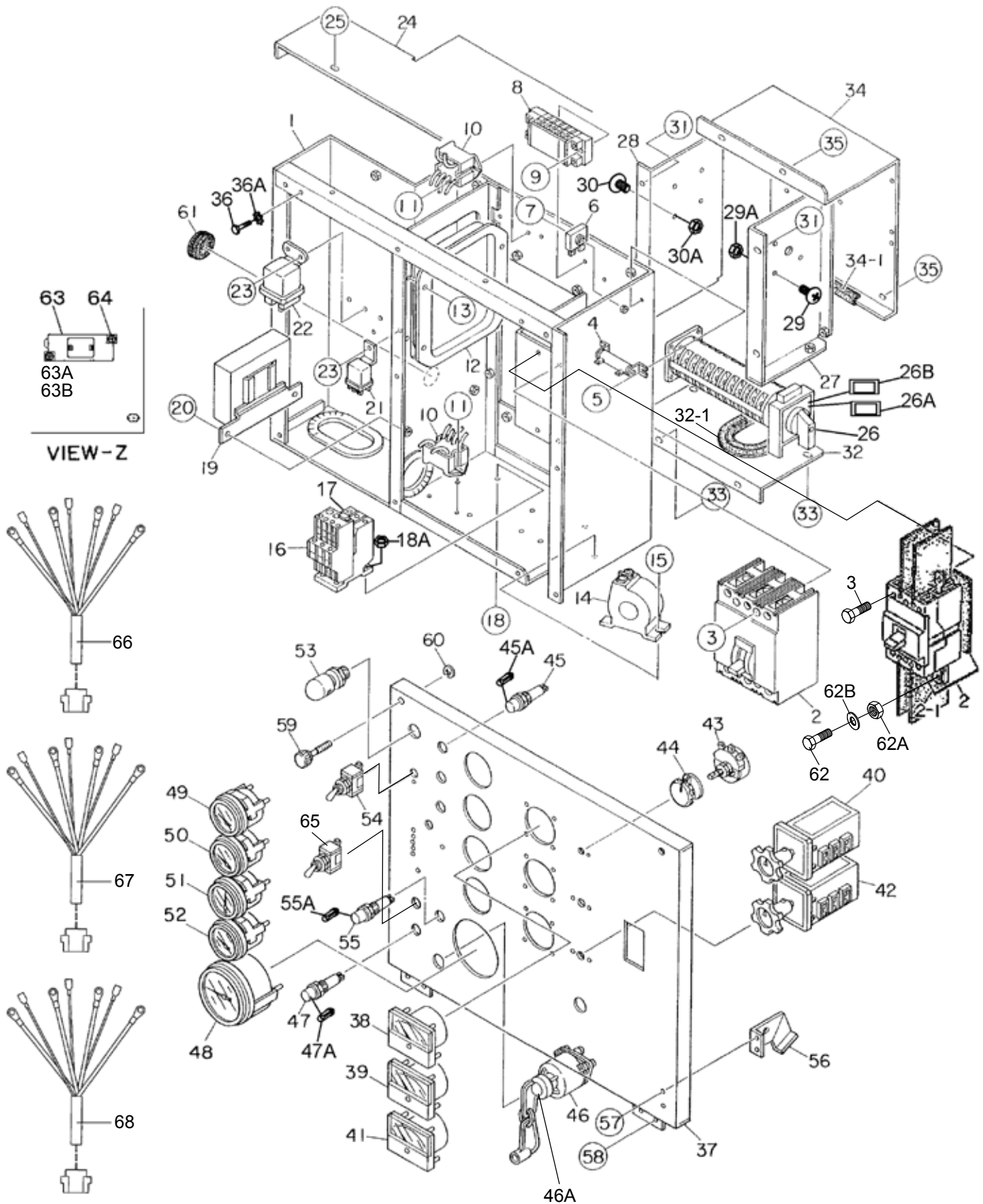



## CONTROL BOX ASSY.

<u>NO.</u>	<u>PART NO.</u>	<u>PART NAME</u>	<u>QTY.</u>	<u>REMARKS</u>
1	M1214000702	CONTROL BOX	1	
2	0601807520	CIRCUIT BREAKER,60A T.C. 12V DC	1	
2-1	0601827411	EF TERMINAL, KT1EF-3	2	
3	0021005080	MACHINE SCREW	4	
4	0601842384	RESISTOR	1	
5	0027104010	MACHINE SCREW	2	
6	0601823240	RECTIFIER	2	
7	0027104030	MACHINE SCREW	1	
8	0601815759	TERMINAL BOARD, 20 6P	1	
9	0027104020	MACHINE SCREW	2	
10	0601823863	RELAY UNIT	2	
11	0027104016	MACHINE SCREW	4	
12	0601820608	AUTOMATIC VOLTAGE REGULATOR	1	
13	0027105016	MACHINE SCREW	4	
14	0601801122	CURRENT TRANSFORMER	3	
15	0027106020	MACHINE SCREW	6	
16	0601820847	OVER CURRENT RELAY	1	
17	0601820848	OVER CURRENT RELAY	1	
18	0027104020	MACHINE SCREW	2	
18A	0207004000	SELF-LOCKING NUT	2	
19	8973259120	ENGINE CONTROLLER.....	1.....	REPLACES P/N 0602202523
20	0016906016	HEX HEAD BOLT	2	
21	5825500290	RELAY .....	2.....	REPLACES P/N 0602201400
22	8944001061	GLOW RELAY.....	1.....	REPLACES P/N 0602202502
23	0027105016	MACHINE SCREW	4	
24	M1213500403	CONTROL BOX COVER	1	
25	0016906016	HEX HEAD BOLT	4	
26	M1270100504	SELECTOR SWITCH	1	
26A	M1550002504	DECAL : SELECTOR SWITCH NUMBER	1	
26B	M1550002604	DECAL : SELECTOR SWITCH NUMBER	1	
27	M1213601404	SWITCH BRACKET	1	
28	M1213601504	SWITCH BRACKET	1	
29	0021104035	MACHINE SCREW	4	
29A	0207004000	SELF- LOCKING NUT	4	
30	0027104016	MACHINE SCREW	4	
30A	0207004000	SELF-LOCKING NUT	4	
31	0016906016	HEX HEAD BOLT	4	
32	M1213601704	SWITCH COVER	1	
32-1	0317700180	SEAL RUBBER	1	
33	0016906016	HEX HEAD BOLT	4	
34	M1213601604	SWITCH COVER	1	
34-1	0330000070	SEAL RUBBER	1	
35	0016906016	HEX HEAD BOLT	6	
36	0016906016	HEX HEAD BOLT	10	
36A	0040506000	TOOTHED WASHER	1	

# CONTROL BOX ASSY. (CONTINUED)

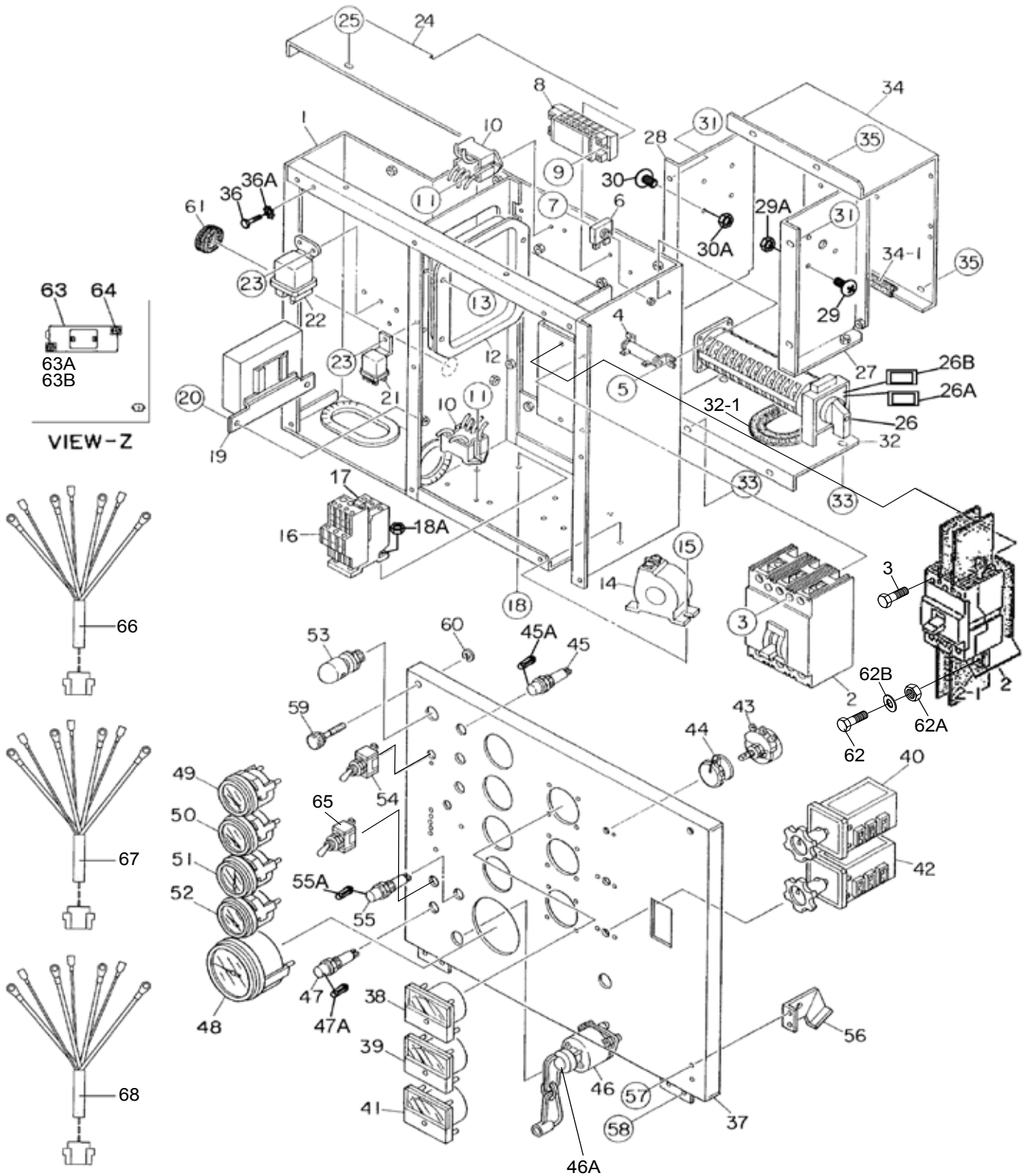

## CONTROL BOX ASSY. (CONTINUED)

<u>NO.</u>	<u>PART NO.</u>	<u>PART NAME</u>	<u>QTY.</u>	<u>REMARKS</u>
37	M1223000613	CONTROL PANEL	1	
38	0601807641	FREQUENCY METER,240V	1	
39	0601808985	AC METER. 0~50A/100A:5A1	1	
40	0601801040	CHANGE-OVER SWITCH, AMMETER	1	
41	0601806859	AC VOLTMETER, 0~600V	1	
42	0601801041	CHANGE-OVER SWITCH, VOLTMETER	1	
43	0601840073	RHEOSTAT VR, 2W 1k OHM	1	
44	0601840121	KNOB	1	
45	0602103092	ALARM LAMP	3	
45A	0601810245	BULB	3	
46	8970444180	STARTER SWITCH .....	1	REPLACES P/N 0602100009
46A	8944024980	KEY, IGNITION	1	
47	0602103092	PREHEAT LAMP	1	
47A	0601810245	BULB	1	
48	0602120095	TACHOMETER	1	
49	0602122093	OIL PRESSURE GAUGE	1	
50	0602123098	WATER TEMPERATURE GAUGE	1	
51	0602121080	CHARGING AMMETER	1	
52	0602125090	FUEL GAUGE	1	
53	9826800370	PANEL LIGHT .....	1	REPLACES P/N 0601810141
54	0601831330	PANEL LIGHT SWITCH	1	
55	0602103092	ALARM LAMP	1	
55A	0601810245	BULB	1	
56	M1225100004	STOPPER	1	
57	0027105010	MACHINE SCREW	2	
58	0027105010	MACHINE SCREW	4	
59	M9220100004	SET SCREW	2	
60	0080200007	SNAP RING	2	
61	0601851727	GROMMET	1	
62	0017108030	HEX HEAD BOLT	6	
62A	0030008000	HEX NUT	6	
62B	0041208000	WASHER, FLAT	6	
63	LY2DUS12VDC	RELAY .....	1	REPLACES P/N 0601827656
63A	PTF08A	RELAY BASE .....	1	REPLACES P/N 0601823109
63B	PYCA1	RELAY CLIP .....	2	REPLACES P/N 0601824400
64	0027104020	SCREW, MACHINE	2	
65	0601831331	TOGGLE SWITCH	1	
66	M1246703614	WIRE HARNESS, GENERATOR	1	
67	M1357201802	WIRE HARNESS, ENGINE	1	
68	M1358200603	WIRE HARNESS, COLD WEATHER KIT	1	

# ENGINE AND RADIATOR ASSY.

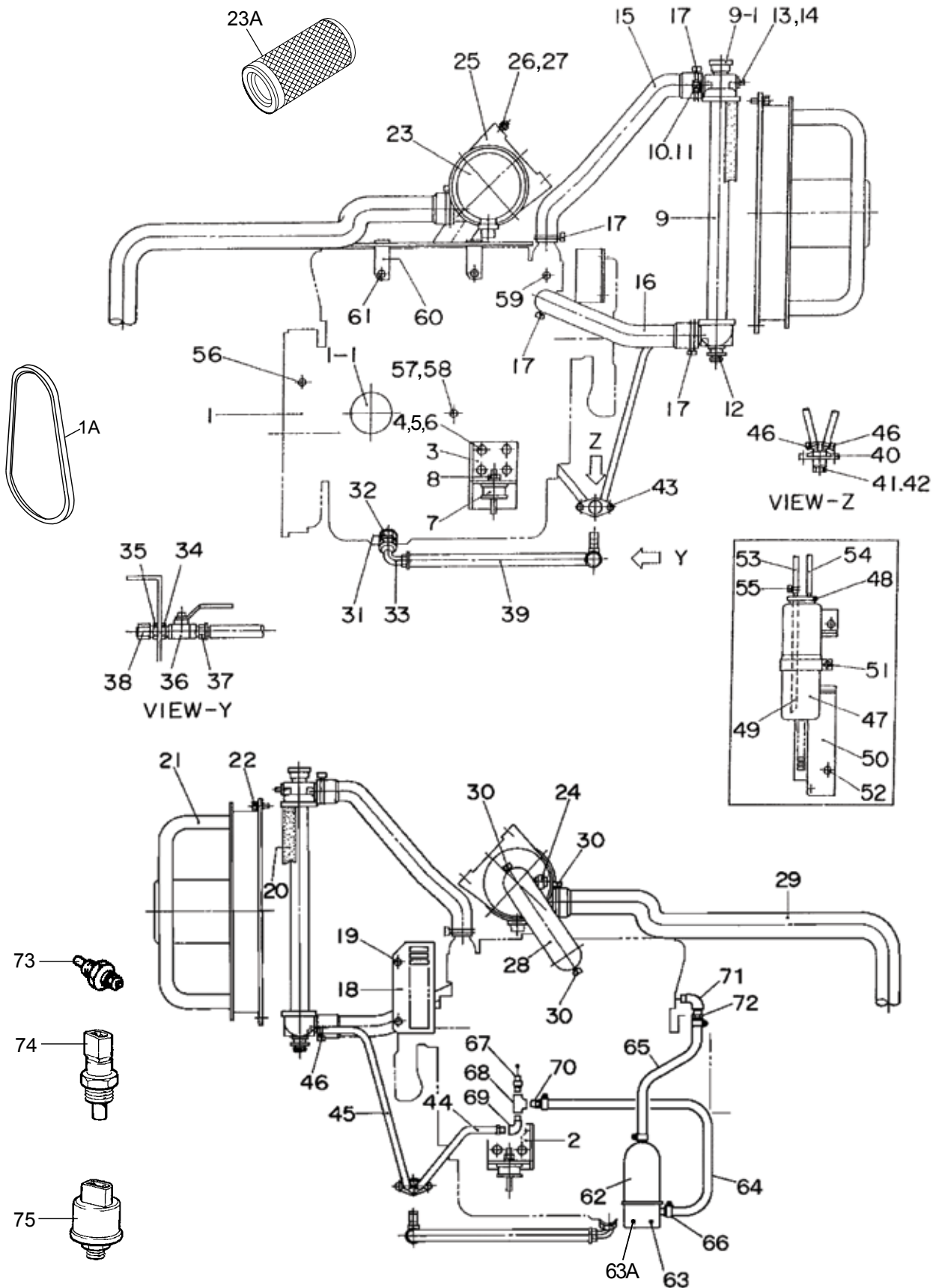

## ENGINE AND RADIATOR ASSY.

<u>NO.</u>	<u>PART NO.</u>	<u>PART NAME</u>	<u>QTY.</u>	<u>REMARKS</u>
1	M1924200094	ENGINE, ISUZU BV4LE2	1	
1A	8972309390	FAN BELT .....	1	REPLACES P/N 0602011431
1-1	2944566410	ELEMENT, OIL FILTER.....	1	REPLACES P/N 0602041210
		.....		AND 8944567412
2	M1305200304	ENGINE FOOT	1	
3	M1305200204	ENGINE FOOT	1	
4	0010310025	HEX HEAD BOLT	8	
5	0040010000	WASHER, LOCK	8	
6	0041210000	WASHER, FLAT	8	
7	0605000066	RUBBER SUSPENSION	2	
8	0207010000	HEX NUT	2	
9	M1923200074	RADIATOR	1	
9-1	0602011079	CAP, RADIATOR	1	
10	M9200100904	PLUG	1	
11	0150000016	O-RING	1	
12	M9312200104	MOUNT RUBBER	2	
13	0016908035	HEX HEAD BOLT	2	
14	0207008000	HEX NUT	2	
15	M1312500203	RADIATOR HOSE, UPPER	1	
16	M1312500303	RADIATOR HOSE, LOWER	1	
17	0605515149	HOSE BAND	4	
18	M1312300103	FAN COVER	1	
19	0016906020	HEX HEAD BOLT	4	
20	0220300425	SEAL RUBBER	2	
21	0601822794	MOTOR FAN	1	
22	0017108025	HEX HEAD BOLT	4	
23	0602046531	AIR CLEANER	1	
23A	0602046611	ELEMENT, AIR CLEANER	1	
24	0602040650	INDICATOR, AIR CLEANER	1	
25	0602040552	BRACKET, AIR CLEANER	1	
26	0016908030	HEX HEAD BOLT	2	
27	0207008000	HEX NUT	2	
28	M1375100303	HOSE, AIR CLEANER	1	
29	M1373101403	HOSE, AIR CLEANER	1	
30	0605515147	HOSE BAND	3	
31	0602022560	ADAPTER	1	
32	M1320300304	PACKING	1	
33	0602022561	90° ELBOW	1	
34	0603306590	CONNECTOR	1	

# ENGINE AND RADIATOR ASSY. (CONTINUED)

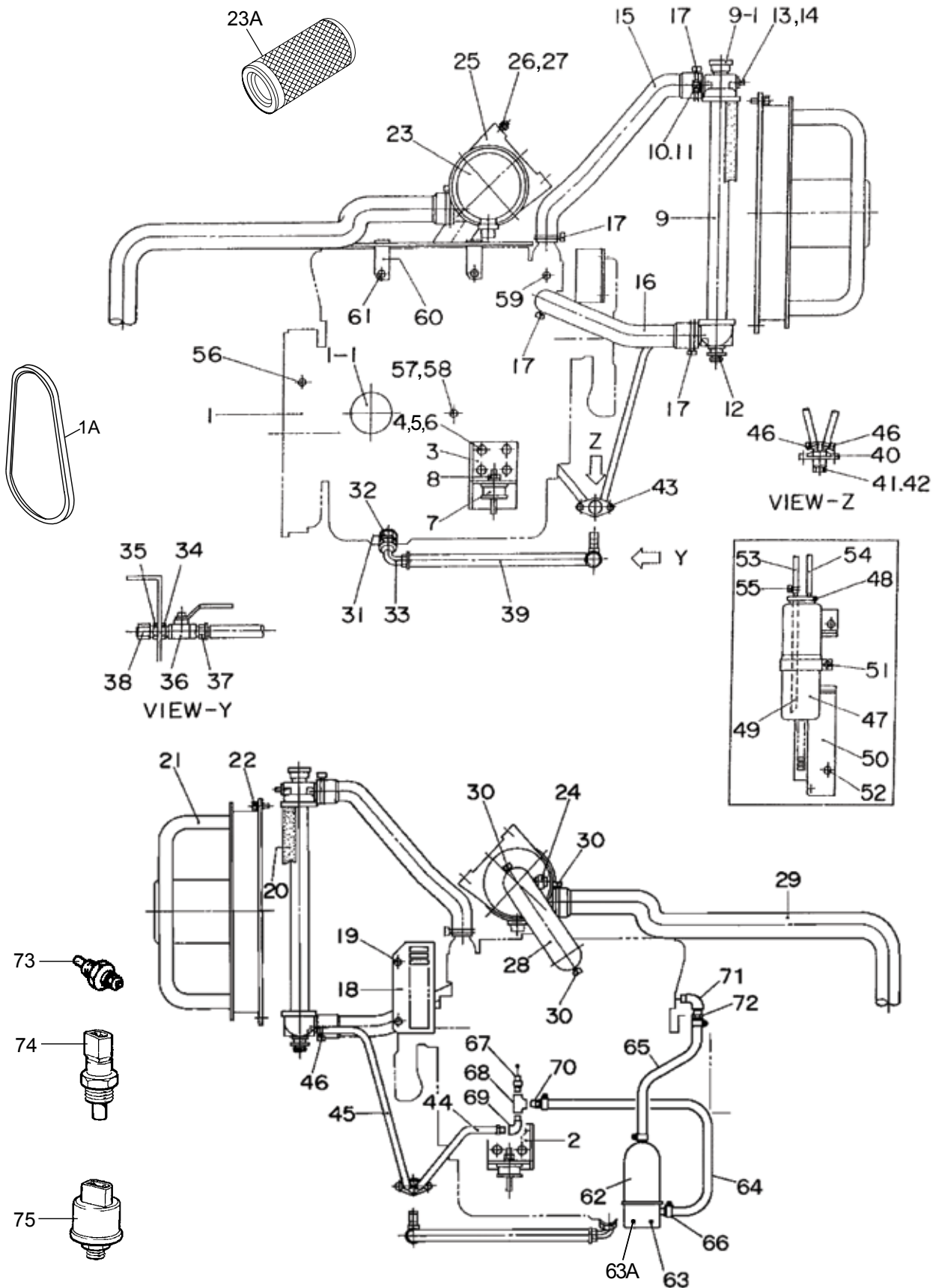

## ENGINE AND RADIATOR ASSY. (CONTINUED)

<u>NO.</u>	<u>PART NO.</u>	<u>PART NAME</u>	<u>QTY.</u>	<u>REMARKS</u>
35	0603300285	LOCKNUT	1	
36	0605511395	VALVE	1	
37	0603306395	HOSE JOINT	1	
38	0602021070	CAP	1	
39	0269200520	DRAIN HOSE	1	
40	M9602000003	DRAIN JOINT	1	
41	M9200200004	PLUG	1	
42	0150000018	O-RING	1	
43	0016906020	HEX HEAD BOLT	2	
44	0199901600	DRAIN HOSE	1	
45	0199900800	DRAIN HOSE	1	
46	0605515106	HOSE BAND	4	
47	M9300000003	RESERVE TANK	1	
48	M9300100003	CAP, RESERVE TANK	1	
49	0199100215	HOSE	1	
50	M1316100603	BRACKET, RESERVE TANK	1	
51	0016906025	HEX HEAD BOLT	1	
52	0016908020	HEX HEAD BOLT	2	
53	0199100700	HOSE	1	
54	0193600850	HOSE	1	
55	0605515106	HOSE BAND	2	
56	0602120481	PICK UP, TACHOMETER	1	
57	0602122272	UNIT, OIL PRESSURE	1	
58	M9200100004	ADAPTER	1	
59	0602123275	UNIT,WATER TEMPERATURE	1	
60	M1353800004	CLAMPER ROD	1	
61	0016908020	HEX HEAD BOLT	2	
62	EE44558	WATER HEATER .....	1.....	REPLACES P/N 0602014270
63	0019206020	HEX. HEAD BOLT	2	
63A	0207006000	HEX. NUT	2	
64	0269300720	HOSE	1	
65	0269300600	HOSE	1	
66	0605515198	HOSE BAND	4	
67	0131502000	NIPPLE	1	
68	0130402000	TEE	1	
69	0130202000	STREET ELBOW	1	
70	0602022939	HOSE JOINT	1	
71	0130204000	STREET ELBOW	1	
72	0602022292	HOSE JOINT	1	
73	8970633010	SENSOR, WATER TEMP.	1	
74	8973022030	SWITCH, WARNING, OVERHEAT	1	
75	1824100990	SENSOR, OIL PRESSURE .....	1.....	REPLACES P/N 5824100362

# OUTPUT TERMINAL ASSY.

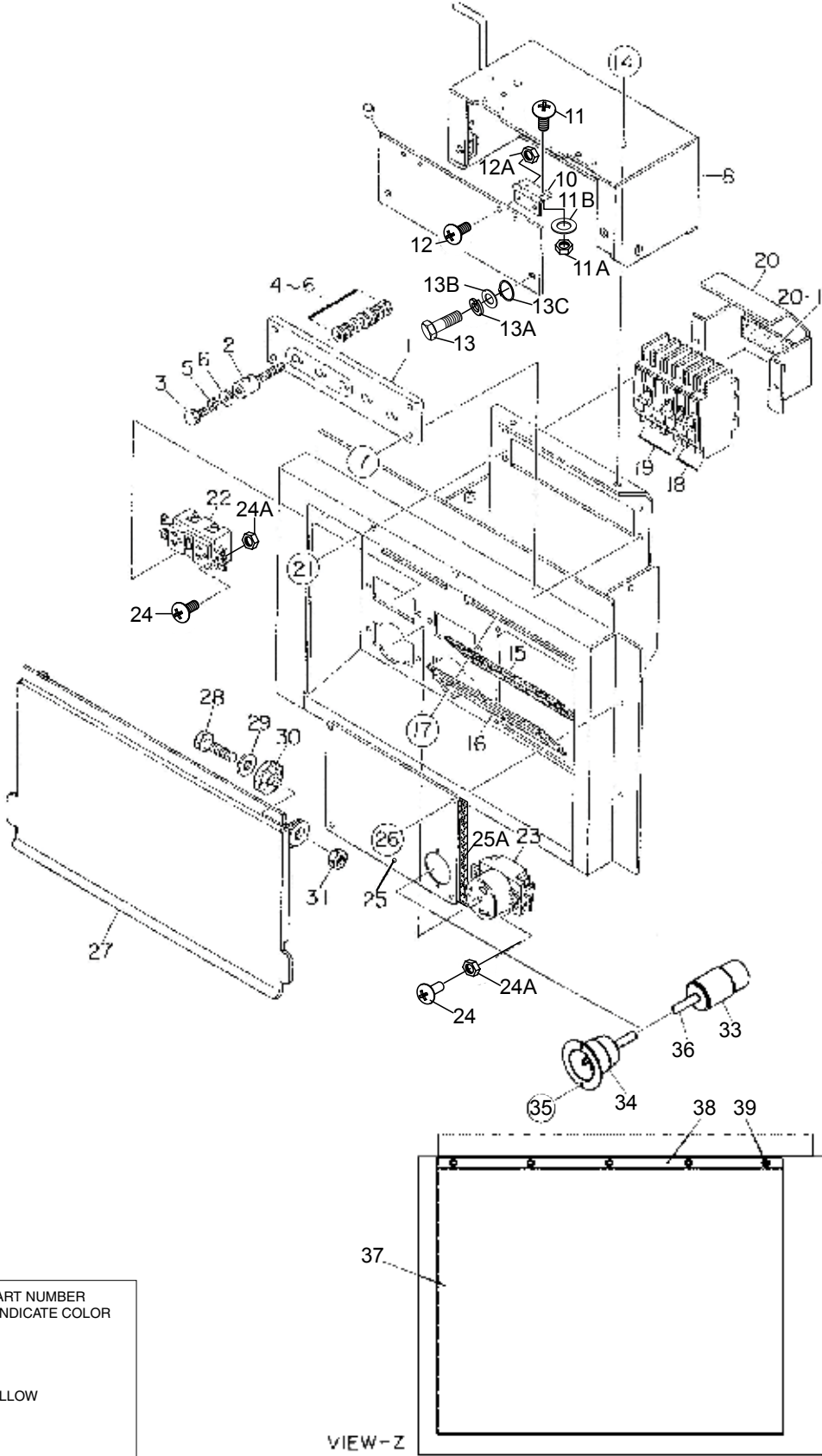

ADD THE FOLLOWING DIGITS AFTER THE PART NUMBER WHEN ORDERING ANY PAINTED PANEL TO INDICATE COLOR OF UNIT.

- |                 |                      |
|-----------------|----------------------|
| 1-ORANGE        | 6-CATERPILLAR YELLOW |
| 2-WHITE         | 7-CATO GOLD          |
| 3-SPECTRUM GREY | 8-RED                |
| 4-SUNBELT GREEN | 9-DESERT TAN         |
| 5-BLACK         |                      |

THE SERIAL NUMBER MAY BE REQUIRED.



## OUTPUT TERMINAL ASSY.

<u>NO.</u>	<u>PART NO.</u>	<u>PART NAME</u>	<u>QTY.</u>	<u>REMARKS</u>
1	M1230700003	TERMINAL PANEL	1	
2	M9220000004	OUTPUT TERMINAL BOLT	5	
3	M9220000104	TIE BOLT	5	
4	0039308000	HEX NUT	10	
5	0040008000	WASHER, LOCK	15	
6	0041408000	WASHER, FLAT	20	
7	0016906025	HEX HEAD BOLT	4	
8	M1236101103	TERMANAL COVER	1	
9	M1238100704	OUTPUT WINDOW	1	
10	0605010040	HINGE	2	
11	0027103010	MACHINE SCREW	4	
11A	0030003000	HEX NUT	4	
11B	0041203000	WASHER, FLAT	4	
12	0027103010	MACHINE SCREW	4	
12A	0030003000	HEX NUT	4	
13	M9220100804	SET SCREW	2	
13A	0040006000	WASHER, LOCK	2	
13B	0041206000	WASHER, FLAT	2	
13C	0080200005	RETAINING RING	2	
14	0016906016	HEX HEAD BOLT	4	
15	M1236400004	OUTLET COVER CABLE	1	
16	M1236300004	CABLE OUTLET COVER SUPPORTER	1	
17	0016906020	HEXHEAD BOLT	6	
18	0601808803	CIRCUIT BREAKER,20A	1	
19	0601808804	CIRCUIT BREAKER, 50A	2	
20	M1260700204	BREAKER FITTING COVER	1	
20-1	0222100115	CUSHION RUBBER	1	
21	0016906020	HEX. HEAD BOLT	2	
22	0601812598	RECEPTACLE, GFCI 125V 20AX2	2	
23	0601814014	RECEPTACLE, CS6369L, 250V V50A	2	
24	0027104016	MACHINE SCREW	8	
24A	0207004000	HEX NUT	8	
25	M1454700304	COVER	1	
25A	M1493408804	ACOUSTIC SHEET	1	
26	0016906016	HEX HEAD BOLT	4	
27	M1238100503	TERMINAL COVER	1	
28	0010112040	HEX HEAD BOLT	2	
29	0041212000	WASHER, FLAT	2	
30	M9310200004	RUBBER STAY	2	
31	0030012000	HEX NUT	2	
33	HBL5269C	CONNECTOR.....	1.....	REPLACES P/N 0601812527
34	HBL5278C	RECEPTACLE .....	1.....	REPLACES P/N 0601811177
35	0027104015	MACHINE SCREW	2	
36	M1358200804	WIRE HARNESS, WATER HEATER	1	
37	M1454700504	RUBBER SHEET	1	
38	M1454700704	RUBBER SHEET HOLDER	1	
39	0605053010	SELF DRILLING SCREW	5	

# BATTERY ASSY.

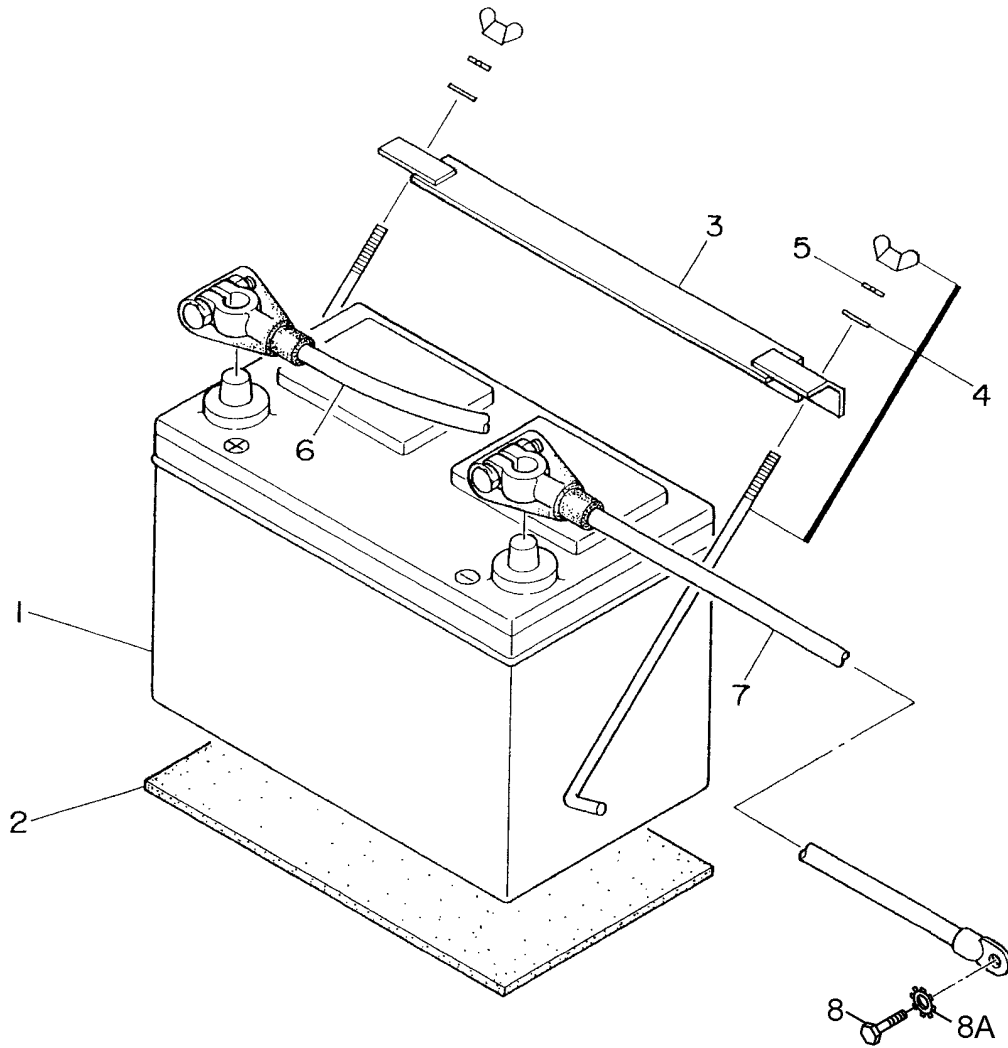

## **BATTERY ASSY.**

---

<u>NO.</u>	<u>PART NO.</u>	<u>PART NAME</u>	<u>QTY.</u>	<u>REMARKS</u>
1	0602220185	BATTERY	1	
2	M9310500014	BATTERY SHEET	1	
3	M9103000304	BATTERY BAND	1	
4	0602220920	BATTERY BOLT SET	2	
5	0040006000	WASHER, LOCK	2	
6	M1348400204	BATTERY CABLE	1	
7	M1348400314	BATTERY CABLE	1	
8	0016910020	HEX HEAD BOLT	1	
8A	0040510000	TOOTHED WASHER	1	

# MUFFLER ASSY.

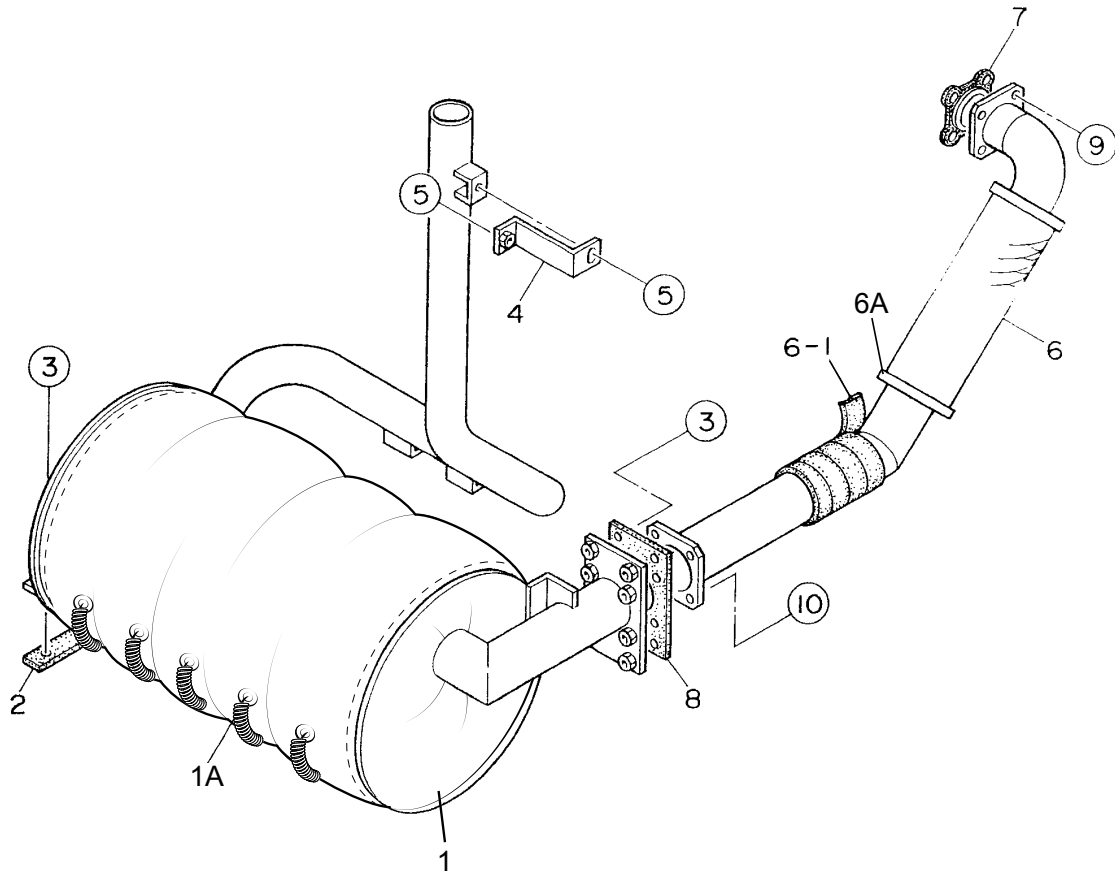

## MUFFLER ASSY.

---

<u>NO.</u>	<u>PART NO.</u>	<u>PART NAME</u>	<u>QTY.</u>	<u>REMARKS</u>
1	M1330000512	MUFFLER	1	
1A	0602302090	MUFFLER BLANKET	1	
2	M1333200304	GASKET	1	
3	0016908035	HEX HEAD BOLT	6	
4	M1333300204	STAY	1	
5	0016908020	HEX. HEAD BOLT	2	
6	M1333003013	EXHAUST PIPE	1	
6A	0605515146	HOSE BAND	2	
6-1	M1490003604	HEAT INSULATOR	1	
7	8970420280	GASKET .....	1	REPLACES P/N 0602320100
8	M1333200214	GASKET	1	
9	0207008000	HEX NUT	4	
10	0016908035	HEX HEAD BOLT	4	

# FUEL TANK ASSY.

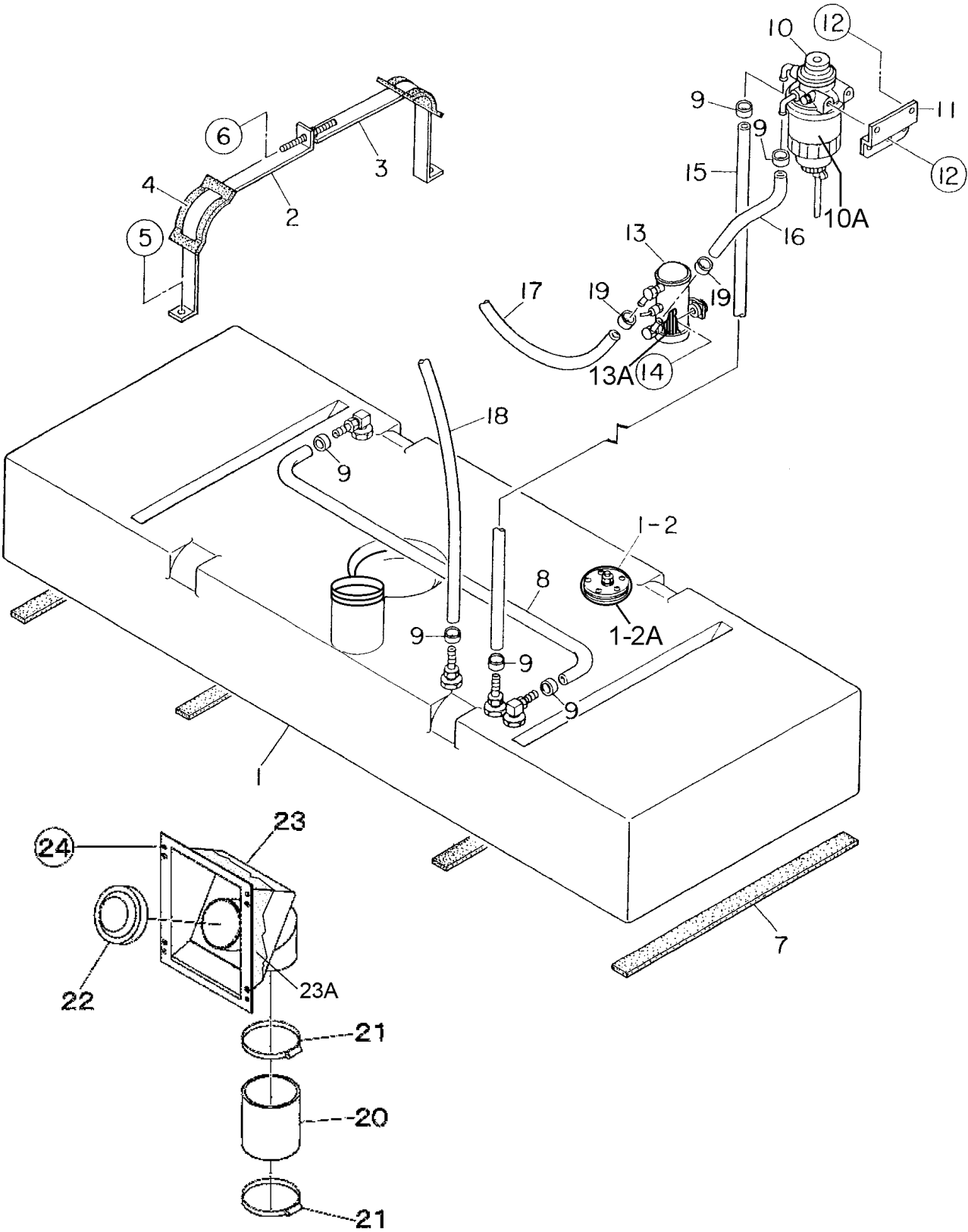

## FUEL TANK ASSY.

<u>NO.</u>	<u>PART NO.</u>	<u>PART NAME</u>	<u>QTY.</u>	<u>REMARKS</u>
1	M1365000302	FUEL TANK	1	
1-2	0605501071	FUEL SENDER UNIT	1	
1-2A	0605516090	GASKET	1	
2	M1365200204	TANK BAND	2	
3	M1363200304	TANK BAND	2	
4	M9310500104	SUPPORTER SHEET	4	
5	0016908020	HEX HEAD BOLT	4	
6	0207008000	HEX NUT	4	
7	0222100550	TANK SHEET	4	
8	0191301200	VENT HOSE	1	
9	0605515109	HOSE BAND	7	
10	8943672922	FUEL FILTER ASSY.....	1	REPLACES P/N 0602042202
10A	89803744810	CARTRIDGE, FUEL FILTER.....	1	REPLACES P/N 0602042700 AND 8943692993
11	M1368700004	BRACKET, FUEL FILTER	1	
12	0016908020	HEX HEAD BOLT	4	
13	8970398340	FUEL PUMP ASSY.....	1	REPLACES P/N 0602023177
13A	8944370220	REPAIR KIT FUEL PUMP.....	1	REPLACES P/N 0602042425
14	0016906030	HEX HEAD BOLT	2	
15	0191200330	SUCTION HOSE	1	
16	0191200200	SUCTION HOSE	1	
17	0191201000	SUCTION HOSE	1	
18	0191200600	RETURN HOSE	1	
19	0605515198	HOSE BAND	3	
20	M1367700204	HOSE,FUEL FILLER	1	
21	0605515225	HOSE BAND	2	
22	0605505072	CAP, FUEL TANK	1	
23	M1484600003	BRACKET, FUEL FILLER	1	
23A	M1494600004	ACCOUSTIC SHEET	1	
24	0019208020	HEX. HEAD BOLT	4	

# ENCLOSURE ASSY.

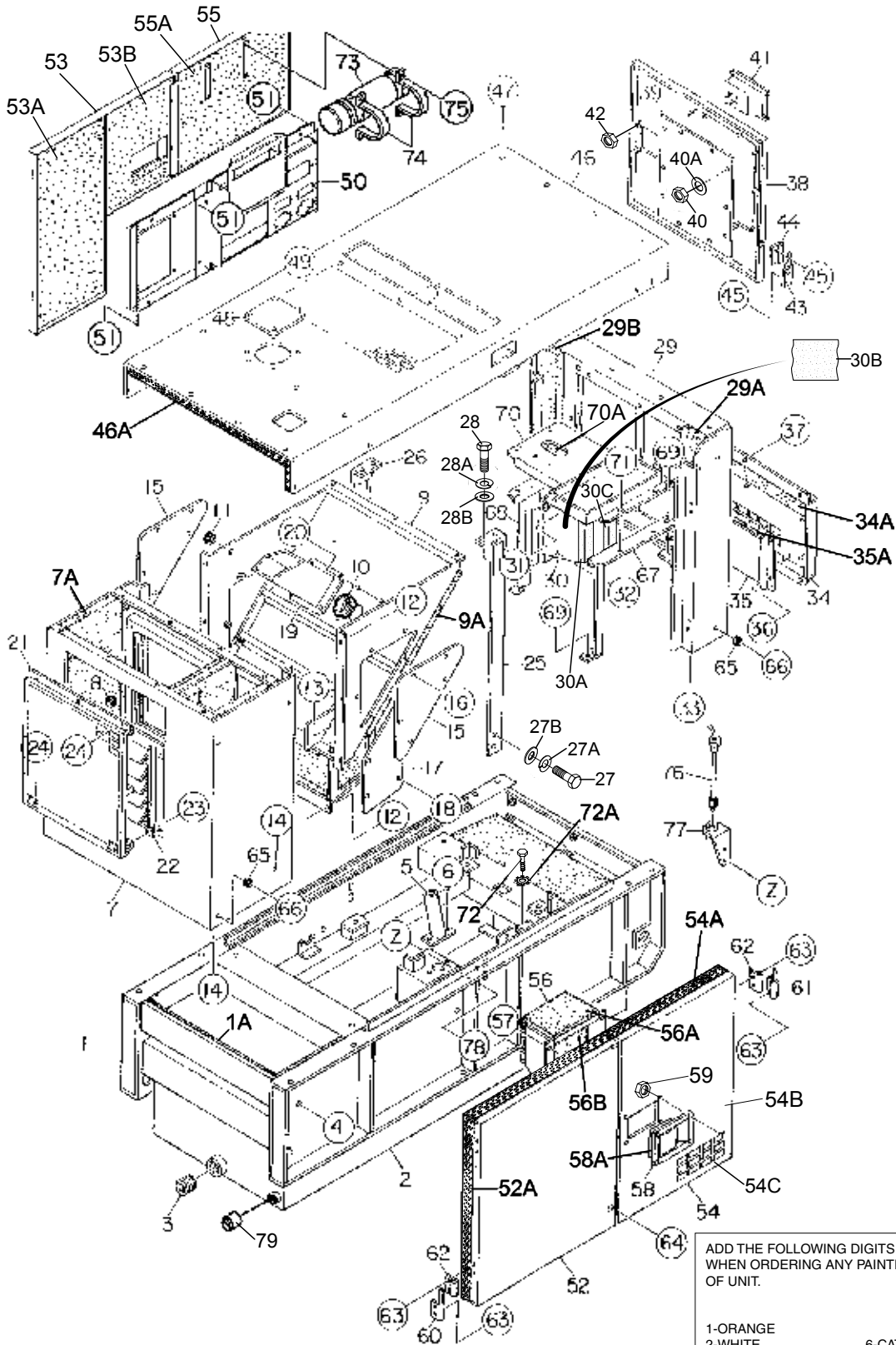

ADD THE FOLLOWING DIGITS AFTER THE PART NUMBER WHEN ORDERING ANY PAINTED PANEL TO INDICATE COLOR OF UNIT.

1-ORANGE	6-CATERPILLAR YELLOW
2-WHITE	7-CATO GOLD
3-SPECTRUM GREY	8-RED
4-SUNBELT GREEN	9-DESERT TAN
5-BLACK	

THE SERIAL NUMBER MAY BE REQUIRED.



## ENCLOSURE ASSY.

<u>NO.</u>	<u>PART NO.</u>	<u>PART NAME</u>	<u>QTY.</u>	<u>REMARKS</u>
1	M1414000802	BASE	1	
1A	M1493000504	ACOUSTIC SHEET	1	
2	M1415100202	ENVIROMENTAL TANK	1	
3	0603306797	PLUG	1	
4	0016910030	HEX HEAD BOLT	6	
5	M1413600004	DUCT	1	
6	011008020	HEX HEAD BOLT .....	2.....	REPLACES P/N 0016908020
7	M1423002402	FRONT FRAME	1	
7A	M1493108303	ACOUSTIC SHEET	1	
8	0601850151	GROMMET	1	
9	M1423202602	FRONT DUCT	1	
9A	M1493108003	ACOUSTIC SHEET	1	
10	0601851740	GROMMET	1	
11	0601850239	GROMMET	1	
12	0016908020	HEX HEAD BOLT	10	
13	0016906020	HEX HEAD BOLT	1	
14	0016908020	HEX HEAD BOLT	6	
15	M1425201204	DUCT COVER	2	
16	0016906016	HEX HEAD BOLT	10	
17	M1423202704	DUCT COVER	1	
18	0016906016	HEX HEAD BOLT	5	
19	M1414200803	HOSE COVER	1	
20	0016906020	HEX HEAD BOLT	4	
21	M1423202003	COVER, FRONT FRAME	1	
22	M1423202103	FRONT LOVER	1	
23	0016906016	HEX HEAD BOLT	8	
24	0019208020	HEX HEAD BOLT	5	
25	M1433001403	CENTER FRAME	1	
26	M1434300403	CENTER FRAME	1	
27	0013612030	HEX HEAD BOLT	4	
27A	0040012000	WASHER, LOCK	4	
27B	0041212000	WASHER, FLAT	4	
28	0013612030	HEX HEAD BOLT	4	
28A	0040012000	WASHER, LOCK	4	
28B	0041212000	WASHER, FLAT	4	
29	M1443001502	REAR FRAME	1	
29A	M1493304004	ACOUSTIC SHEET	1	
29B	M1493305304	ACOUSTIC SHEET	1	
30	M1453301703	DUCT	1	
30A	M1493305304	ACOUSTIC SHEET	1	
30B	M1493305404	ACOUSTIC SHEET	1	
30C	M1493305504	ACOUSTIC SHEET	1	

# ENCLOSURE ASSY. (CONTINUED)

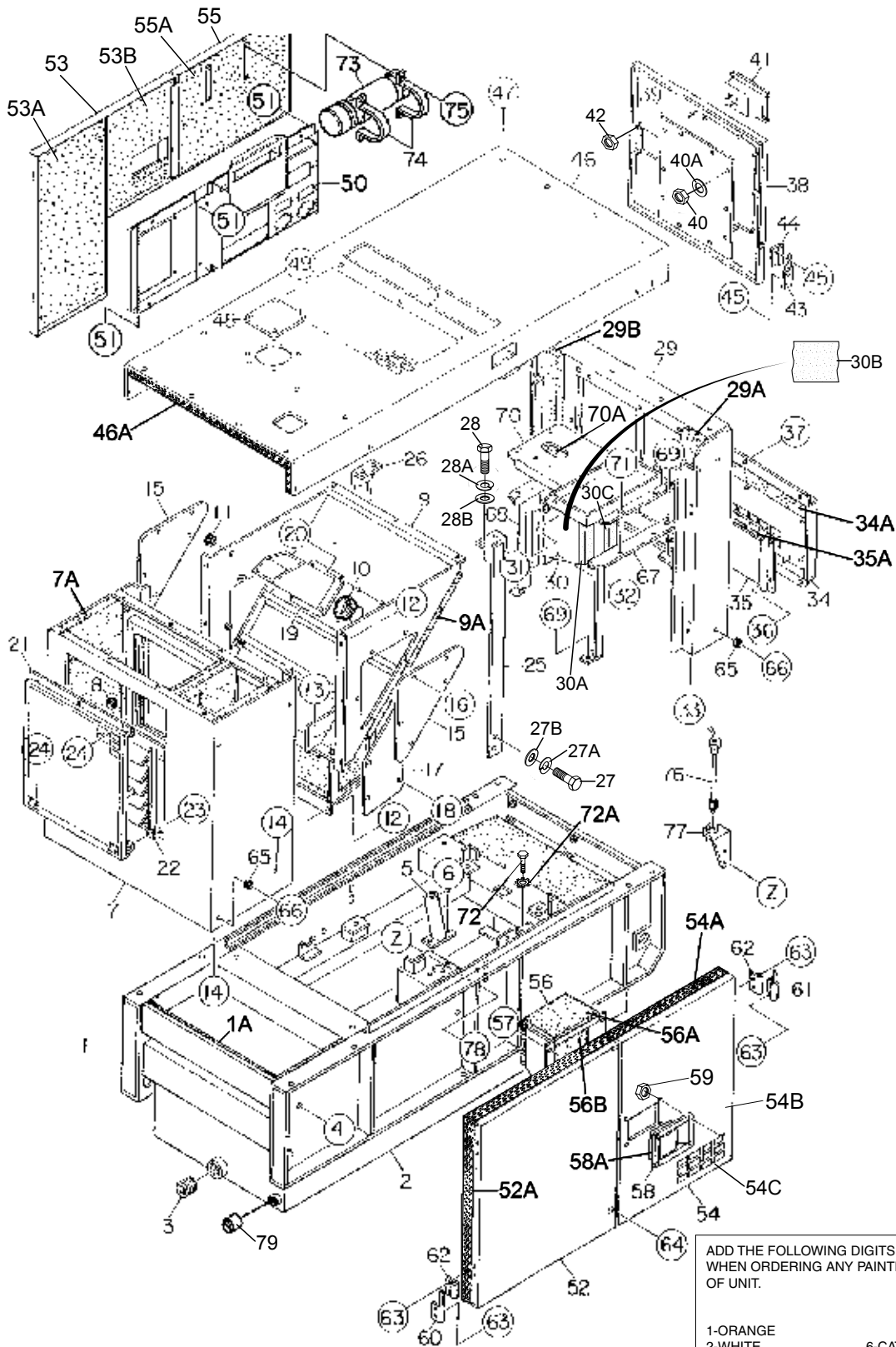

ADD THE FOLLOWING DIGITS AFTER THE PART NUMBER WHEN ORDERING ANY PAINTED PANEL TO INDICATE COLOR OF UNIT.

1-ORANGE	6-CATERPILLAR YELLOW
2-WHITE	7-CATO GOLD
3-SPECTRUM GREY	8-RED
4-SUNBELT GREEN	9-DESERT TAN
5-BLACK	

THE SERIAL NUMBER MAY BE REQUIRED.

## ENCLOSURE ASSY. (CONTINUED)

<u>NO.</u>	<u>PART NO.</u>	<u>PART NAME</u>	<u>QTY.</u>	<u>REMARKS</u>
31	0016906016	HEX HEAD BOLT	1	
32	0207006000	HEX. NUT	2	
33	0016908020	HEX HEAD BOLT	4	
34	M1444300403	REAR COVER	1	
34A	M1493305104	ACOUSTIC SHEET	1	
35	M1443400103	DUCT	1	
35A	M1493305204	ACOUSTIC SHEET	1	
36	0207006000	HEX. NUT	7	
37	0019208020	HEX HEAD BOLT	6	
38	M1444200303	REAR DOOR	1	
39	M1445600204	WINDOW PLATE	1	
40	0207306000	HEX. NUT	10	
40A	0041206000	WASHER, FLAT	10	
41	0605012309	DOOR HANDLE ASSY.	1	
42	0176060030	HEX. NUT .....	4	REPLACES P/N 0207006000
43	M9112100404	HINGE	2	
44	M9112100604	HINGE	2	
45	0016908020	HEX. HEAD BOLT	8	
46	M1463001902	ROOF PANEL	1	
46A	M1493505603	ACOUSTIC SHEET	1	
47	0019208020	HEX HEAD BOLT	23	
48	M3310600004	COVER	1	
49	0019208020	HEX HEAD BOLT	4	
50	M1454200502	SPLASHER PANEL	1	
51	0016908020	HEX. HEAD BOLT	4	
52	M1455100003	SIDE PANEL	1	
52A	M1493410104	ACOUSTIC SHEET	1	
53	M1454001503	SIDE DOOR	1	
53A	M1494405304	ACOUSTIC SHEET	1	
53B	M1494405404	ACOUSTIC SHEET	1	
54	M1454001403	SIDE DOOR	1	
54A	M1495501204	ACOUSTIC SHEET	1	
54B	M1495501304	ACOUSTIC SHEET	1	
54C	M1495401404	ACOUSTIC SHEET	1	

# ENCLOSURE ASSY. (CONTINUED)

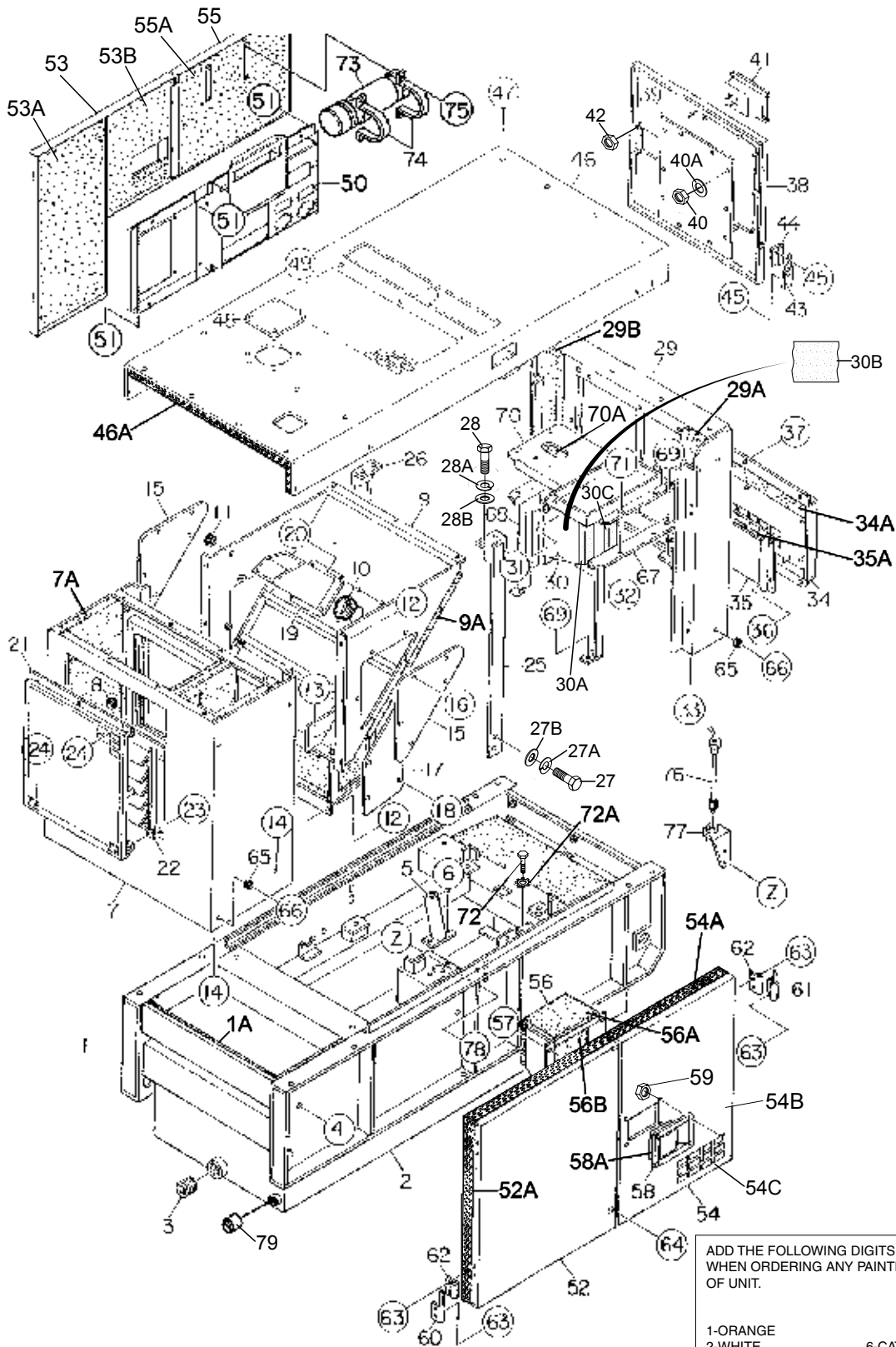

ADD THE FOLLOWING DIGITS AFTER THE PART NUMBER WHEN ORDERING ANY PAINTED PANEL TO INDICATE COLOR OF UNIT.

1-ORANGE	6-CATERPILLAR YELLOW
2-WHITE	7-CATO GOLD
3-SPECTRUM GREY	8-RED
4-SUNBELT GREEN	9-DESERT TAN
5-BLACK	

THE SERIAL NUMBER MAY BE REQUIRED.

## ENCLOSURE ASSY. (CONTINUED)

<u>NO.</u>	<u>PART NO.</u>	<u>PART NAME</u>	<u>QTY.</u>	<u>REMARKS</u>
55	M1453005003	SIDE DOOR	1	
55A	M1493410004	ACOUSTIC SHEET	1	
56	M1455300403	DUCT	1	
56A	M1495401204	ACOUSTIC SHEET	4	
56B	M1495401404	ACOUSTIC SHEET	1	
57	0207006000	HEX. NUT	6	
58	0605012309	DOOR HANDLE ASSY.	2	
58A	C9312500004	SEAL RUBBER	2	
59	0176060030	HEX. NUT .....	8	REPLACES P/N 0207006000
60	M9112100404	HINGE	4	
61	M9112100504	HINGE	4	
62	M9112100604	HINGE	8	
63	011008020	HEX HEAD BOLT .....	32	REPLACES P/N 0016908020
64	011008020	HEX HEAD BOLT .....	2	REPLACES P/N 0016908020
65	0601850097	STOPPER	5	
66	0027208025	MACHINE SCREW	5	
67	M1433300003	BRACKET STAY	1	
68	M1435000803	BRACKET STAY	1	
69	0016908020	HEX HEAD BOLT	4	
70	M1433001103	SUPPORT LEG	1	
70A	M1493200004	ACOUSTIC SHEET	1	
71	0016908020	HEX HEAD BOLT	4	
72	0016908020	HEX HEAD BOLT	1	
72A	0040508000	TOOTHED WASHER	1	
73	0600800321	MANUAL-PAK	1	
74	M1483600804	BOX CLAMPER	2	
75	0016906016	HEX HEAD BOLT	4	
76	0605503066	SWITCH, FUEL LEAK DETECTED	1	
77	M1414800204	BRACKET	1	
78	0017108020	HEX. HEAD BOLT	2	
79	0603306793	PLUG	1	

# RUBBER SEALS ASSY.

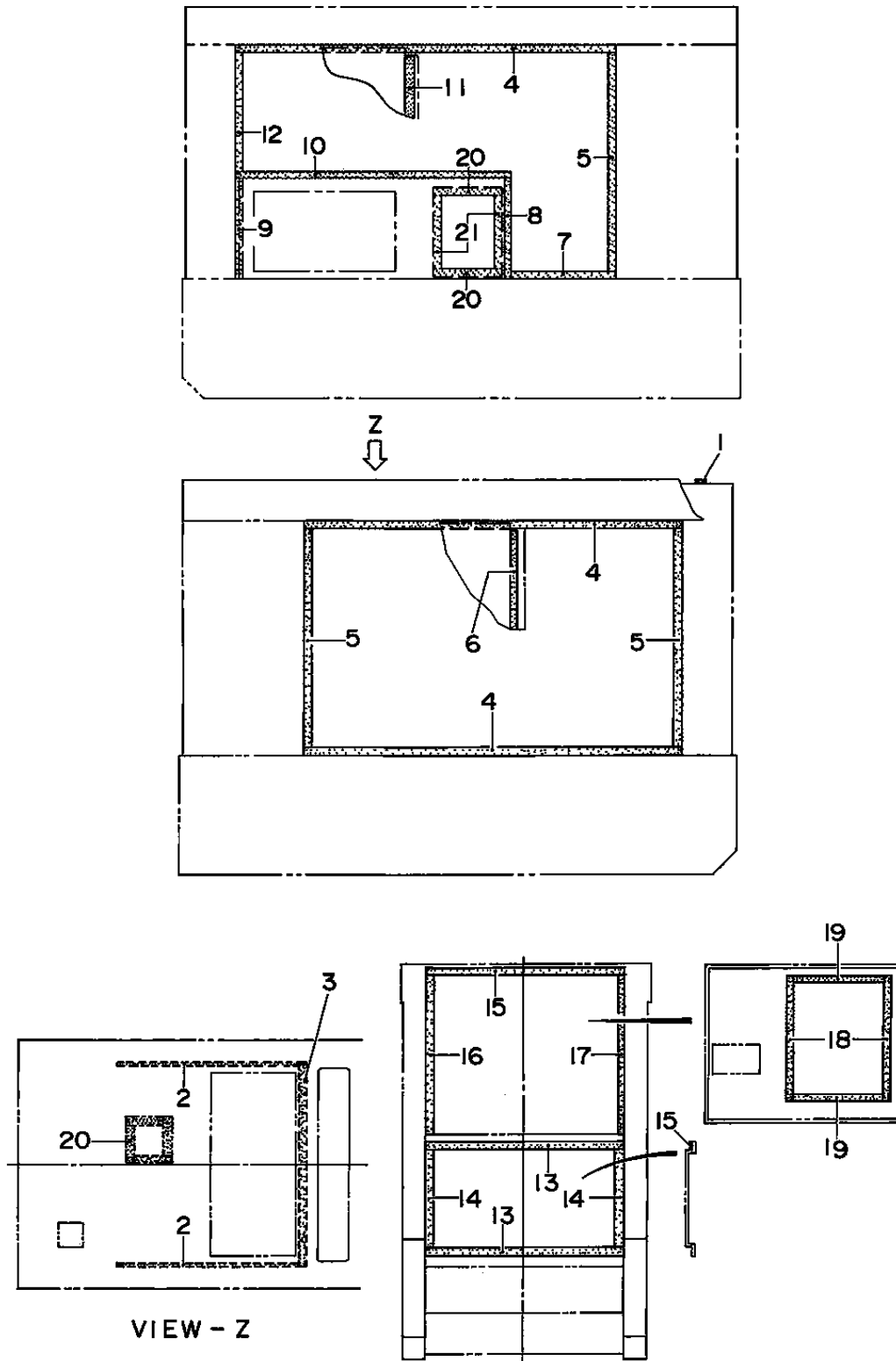

## RUBBER SEALS ASSY.

---

<u>NO.</u>	<u>PART NO.</u>	<u>PART NAME</u>	<u>QTY.</u>	<u>REMARKS</u>
1	0229200790	SEAL RUBBER	3	
2	0314500560	SEAL RUBBER	2	
3	0229900630	SEAL RUBBER	1	
4	0228901220	SEAL RUBBER	3	
5	0228900690	SEAL RUBBER	3	
6	0228800690	SEAL RUBBER	1	
7	0228900340	SEAL RUBBER	1	
8	0228900325	SEAL RUBBER	1	
9	0229200325	SEAL RUBBER	1	
10	0228800880	SEAL RUBBER	1	
11	0228900375	SEAL RUBBER	1	
12	0228900375	SEAL RUBBER	1	
13	0229200650	SEAL RUBBER	2	
14	0229200320	SEAL RUBBER	2	
15	0228800650	SEAL RUBBER	2	
16	0228900510	SEAL RUBBER	1	
17	0228800510	SEAL RUBBER	1	
18	0228100390	SEAL RUBBER	2	
19	0228100320	SEAL RUBBER	2	
20	0229200220	SEAL RUBBER	2	
21	0229200235	SEAL RUBBER	2	

# NAMEPLATE AND DECALS ASSY.

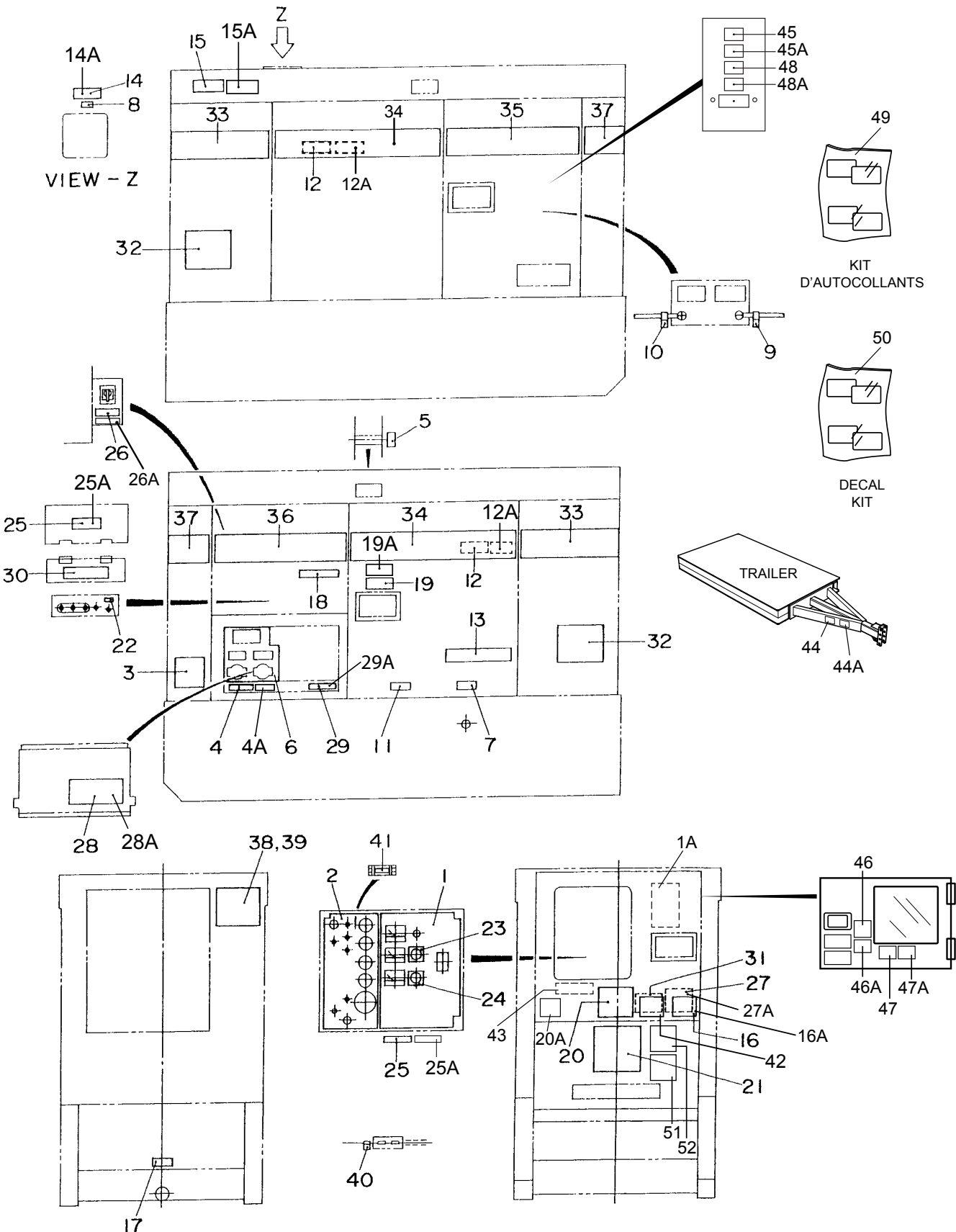



## NAMEPLATE AND DECALS ASSY.

NO.	PART NO.	PART NAME	QTY.	REMARKS
1	M1510300902	DECAL: OPERATING PROCEDURES .....	1 .....	M11030090
1A	TBD	DECAL: OPERATING PROCEDURES (FRENCH)	1	
2	M1510301002	DECAL: GENERATOR CONTROL .....	1 .....	M11030100
3	M1550000104	DECAL: NOTE .....	1 .....	M15000010
4	EE57066	DECAL: NOTICE, 50AMP RECEPTACLES (ENGLISH).....	1 .....	EE57066
4A	EE57067	DECAL: NOTICE, 50AMP RECEPTACLES (FRENCH) .....	1 .....	EE57067
5	M1550001404	DECAL: CAUTION .....	1 .....	M15000140
6	M1552000603	DECAL: AUXILIARY OUTPUT .....	1 .....	M15500060
7	M9500000004	DECAL: OIL DRAIN PLUG .....	1 .....	M90000000
8	M9500100004	DECAL: WATER.....	1 .....	M90010000
9	M9500300004	DECAL: - .....	1 .....	M90030000
10	M9500300104	DECAL: + .....	1 .....	M90030010
11	M9500500304	DECAL: DIESEL FUEL .....	2 .....	M90050000
12	M9503000004	DECAL: WARNING MOVING PARTS (ENGLISH).....	2 .....	M90300000
12A#		DECAL: WARNING MOVING PARTS (FRENCH).....	2 .....	M90300000CE
13	M9503000103	DECAL: WATER - OIL CHECK .....	1 .....	M90300010
14	M9503100004	DECAL: WARNING, HOT COOLANT (ENGLISH).....	1 .....	M90310000
14A#		DECAL: WARNING, HOT COOLANT (FRENCH).....	1 .....	M90310000CE
15	M9503200004	DECAL: WARNING ENGINE EXHAUST (ENGLISH) .....	1 .....	M90320000
15A#		DECAL: WARNING ENGINE EXHAUST (FRENCH) .....	1 .....	MQB90420000CE
16	M9503200104	DECAL: DANGER, EXHAUST GAS (ENGLISH) .....	1 .....	M90320010
16A#		DECAL: DANGER, EXHAUST GAS (FRENCH).....	1 .....	M90320010CE
17	M9510000004	DECAL: FLUID DRAIN .....	1 .....	M91000000
18	M9510000104	DECAL: DOCUMENT BOX.....	1 .....	M91000010
19	M9510100004	DECAL: CAUTION HOT PARTS (ENGLISH).....	1 .....	M91010030
19A#		.....		or M91010000
		DECAL: CAUTION, HOT PARTS (FRENCH).....	1 .....	MQB90400030CE
20	EE57068	DECAL: NOTICE, ENVIRONMENTAL WARNING (ENGLISH). 1 .....		EE57068
20A	EE57069	DECAL: NOTICE, ENVIRONMENTAL WARNING (FRENCH).. 1 .....		EE57069
21	M9512200004	DECAL: MQ .....	1 .....	M91020000
22	M9520000004	DECAL: GROUND .....	1 .....	M92000000
23	M9520000104	DECAL: AMMETER CHANGE - OVER SWITCH .....	1 .....	M92000010
24	M9520000204	DECAL: VOLTMETER CHANGE - OVER SWITCH.....	1 .....	M92000020
25	M9520100004	DECAL: WARNING ELECTRIC SHOCK HAZ.(ENGLISH) .....	2 .....	M92010000
25A#		DECAL: WARNING, ELECTRIC SHOCK HAZ.(FRENCH).....	2 .....	MQB9310050CE
26A	M9520100204A	DECAL: CAUTION, STOP ENGINE (ENGLISH) .....	1 .....	M92010020A
26A#		DECAL: CAUTION, STOP ENGINE (FRENCH) .....	1 .....	M92010020CE
27	M9520100304	DECAL: SAFETY INSTRUCTIONS (ENGLISH).....	1 .....	M92010030
27A#		DECAL: SAFETY INSTRUCTIONS (FRENCH).....	1 .....	B92110040CE
28	M9520100404	DECAL: DANGER HIGH VOLTAGE (ENGLISH).....	1 .....	M92010040
28A#		DECAL: DANGER, HIGH VOLTAGE (FRENCH).....	1 .....	MQS-2731CE
29	M9520100503	DECAL: WARNING, ELECTRICAL (ENGLISH).....	1 .....	M92010050
29A#		DECAL: WARNING, ELECTRICAL (FRENCH) .....	1 .....	M92010050CE
30	M9520200003	DECAL: CONNECTION OF OUTPUT CABLE .....	1 .....	M92020000

# NAMEPLATE AND DECALS ASSY. (CONTINUED)

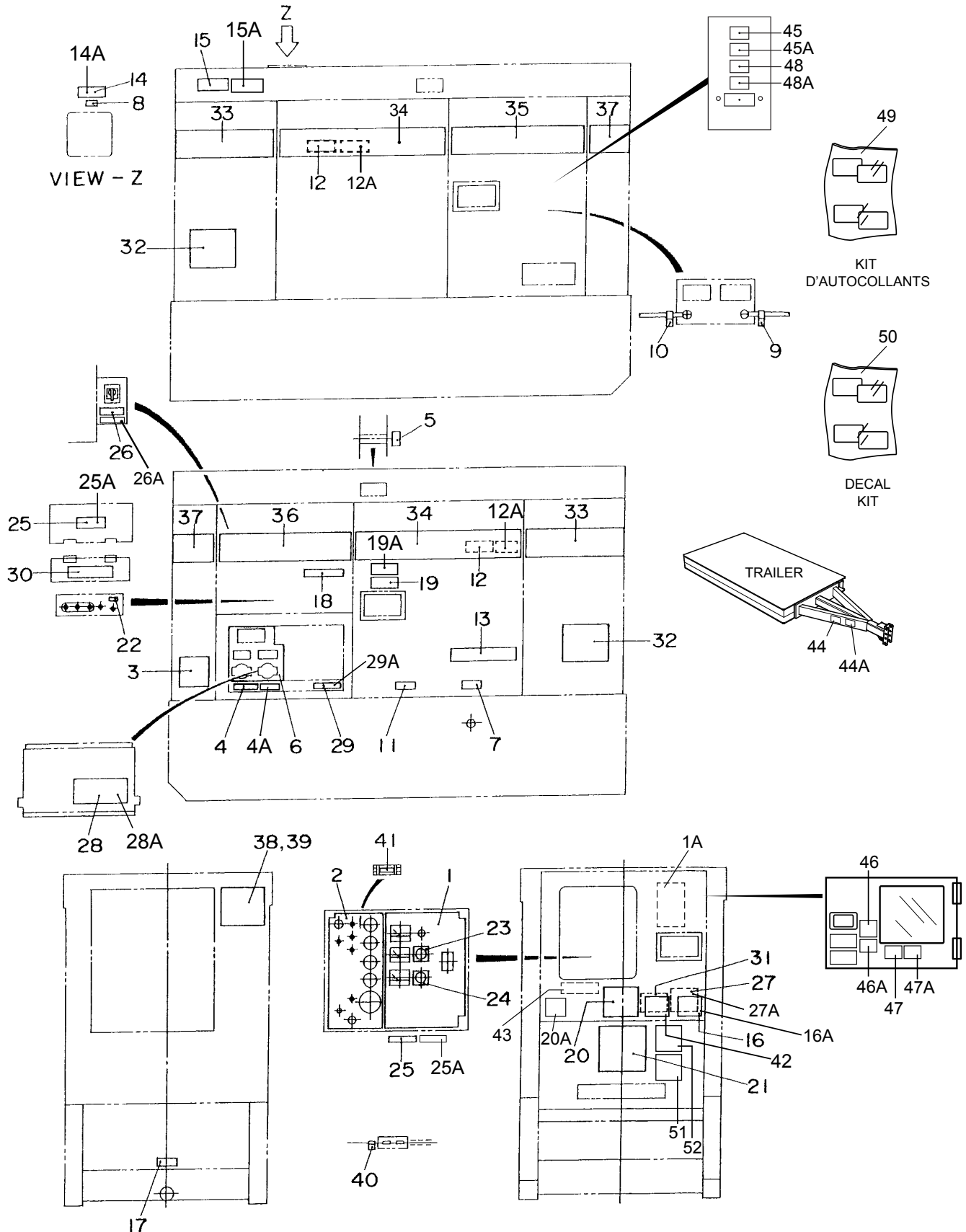

## NAMEPLATE AND DECALS ASSY. (CONTINUED)

NO.	PART NO.	PART NAME	QTY.	REMARKS
31	M9520200404	DECAL: OVER CURRENT RELAY .....	1.....	M92020040
32	M1561000004	DECAL: MQ POWER.....	2	
33	M1562100004	STRIPE.....	2	
34	M1562100103	STRIPE: WHISPERWATT.....	1	
35	M1562100204	STRIPE: 25.....	1	
36	M1562100304	STRIPE: 25.....	1	
37	M1562100404	STRIPE .....	2	
38	0600500092	PLATE: MQ POWER.....	1	
39	0021106016	MACHINE SCREW.....	4	
40	M9520000804	DECAL: AC.....	1.....	M92000080
41	M9521000004	DECAL: TERMINAL.....	1	
42	92021400	DECAL: WARNING START FIRES.....	1.....	REPLACES P/N M9504200004
43	M9531000004	DECAL: NOTICE TEMP. GAUGE.....	1	
44	49002	DECAL: WARNING, TRAILER (ENGLISH).....	1.....	49002
44A#		DECAL: WARNING, TRAILER (FRENCH).....	1.....	490002CE
45\$	EE57072	DECAL: NOTICE, BONDED TO FRAME (ENGLISH).....	1	
45A\$	EE57073	DECAL: NOTICE, BONDED TO FRAME (FRENCH) .....	1	
46\$	EE57077	DECAL: NOTICE, CLASS H (ENGLISH).....	1	
46A\$	EE57078	DECAL: NOTICE, CLASS H (FRENCH).....	1	
47\$	EE57070	DECAL: NOTICE, OVERLOAD (ENGLISH).....	1	
47A\$	EE57071	DECAL: NOTICE, OVERLOAD (FRENCH) .....	1	
48\$	EE57079	DECAL: NOTICE, SUPPLY WIRES (ENGLISH).....	1	
48A\$	EE57080	DECAL: NOTICE, SUPPLY WIRES(FRENCH).....	1	
49	EE52657	DECAL KIT (FRENCH).....	1.....	INCLUDES ITEMS W/#
50	EE57074	DECAL KIT (ENGLISH & FRENCH).....	1.....	INCLUDES ITEMS W/\$
51	EE57635	EMISSION CONTROL NAMEPLATE .....	1.....	EE57635
52		DATA NAMEPLATE; SERIAL NUMBER AND MODEL.....	1.....	CONTACT PARTS DEPT.

# 3Ø 600 VAC TRANSFORMER ASSY. (OPTION)

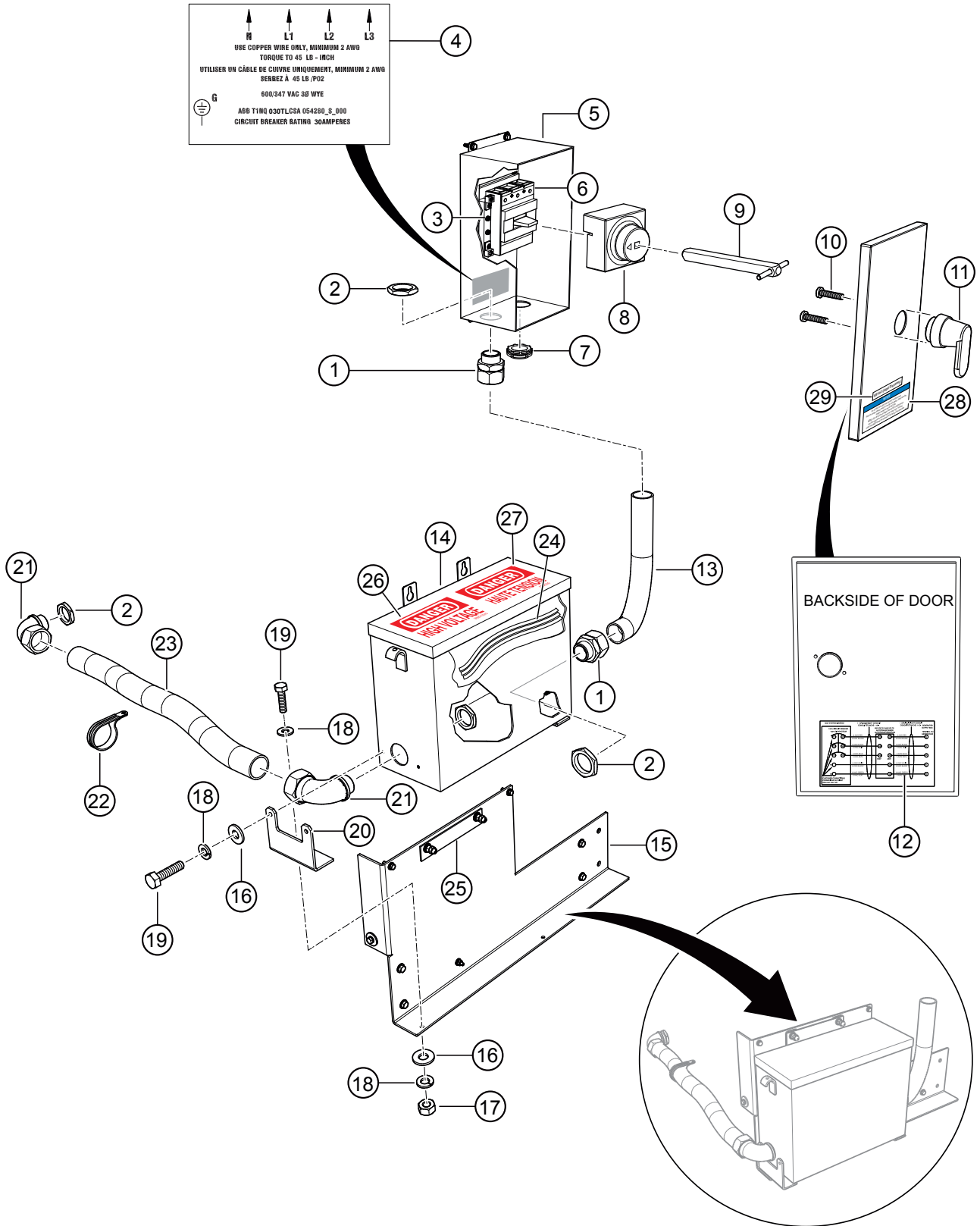

## 3Ø 600 VAC TRANSFORMER ASSY. (OPTION)

<u>NO.</u>	<u>PART NO.</u>	<u>PART NAME</u>	<u>QTY.</u>	<u>REMARKS</u>
1	EE57537	STRAIGHT, LIQUID TIGHT FITTING	2	
2	EE5972	BUSHING, PLAST, 1-1/2"	4	
3	EE57531	KIT, NEUTRAL, BUS BAR	1	
4	EE57772	LABEL, VINYL, CB T1NQ030TL	1	
5	EE57530	ENCLOSURE, NEMA CIRCUIT BREAKER	1	
6	EE52421	CIRCUIT BREAKER T1NQ030TL	1	
7	EE58372	BUSHING, INSULATED WITH NUT	1	
8	EE57532	MECHANISM, CIRCUIT BREAKER OPERATION	1	
9	EE57533	SHAFT	1	
10#		SCREW	2	
11	EE57534	HANDLE, EXTERIOR.....	1.....	INCLUDE ITEMS W#
12	EE57991	LABEL, VINYL, DIAGRAM 600V	1	
13	EE57536	CONDUIT, LIQUIDTIGHT FLEXIBLE 1-1/2".....	10.....	1PC = 1FT
14	EE57617	TRANSFORMER, 600V, 3-PHASE, 30KVA	1	
15	EE57981	BRACKET, 600V TRANSFORMER	1	
16		WASHER, FLAT.....	6.....	OBTAIN LOCALLY
17		NUT.....	6.....	OBTAIN LOCALLY
18		WASHER, LOCK.....	8.....	OBTAIN LOCALLY
19		BOLT, 1/2" X 1-3/4" GRD 8.....	6.....	OBTAIN LOCALLY
20	EE58302	BRACKET, TRANSFORMER SUPPORT	2	
21	EE57538	90°, LIQUIDTIGHT FITTING	2	
22		BRACKET.....	1.....	OBTAIN LOCALLY
23	EE57536	CONDUIT, LIQUIDTIGHT FLEXIBLE.....	10.....	1PC = 1FT
24	EE58355	CABLE, 6 AWG, TYPE THHW-MTW-AWM.....	75.....	1PC = 1FT
25	EE58954	PLATE, REINFORCEMENT, TRANSFORMER BRACKETS	1	
26	M9520100404	DECAL, WARNING HIGH VOLTAGE	1	
27	EE58330	DECAL, "DANGER-HAUTE TENSION"	1	
28	EE58311	DECAL, OUTPUT DISCONNECT INSTRUCTION	1	
29	EE58312	DECAL, "600 VOLT OUTPUT DISCONNECT"	1	

# TERMS AND CONDITIONS OF SALE — PARTS

## PAYMENT TERMS

Terms of payment for parts are net 30 days.

## FREIGHT POLICY

All parts orders will be shipped collect or prepaid with the charges added to the invoice. All shipments are F.O.B. point of origin. Multiquip's responsibility ceases when a signed manifest has been obtained from the carrier, and any claim for shortage or damage must be settled between the consignee and the carrier.

## MINIMUM ORDER

The minimum charge for orders from Multiquip is \$15.00 net. Customers will be asked for instructions regarding handling of orders not meeting this requirement.

## RETURNED GOODS POLICY

Return shipments will be accepted and credit will be allowed, subject to the following provisions:

1. A Returned Material Authorization must be approved by Multiquip prior to shipment.
2. To obtain a Return Material Authorization, a list must be provided to Multiquip Parts Sales that defines item numbers, quantities, and descriptions of the items to be returned.
  - a. The parts numbers and descriptions must match the current parts price list.
  - b. The list must be typed or computer generated.
  - c. The list must state the reason(s) for the return.
  - d. The list must reference the sales order(s) or invoice(s) under which the items were originally purchased.
  - e. The list must include the name and phone number of the person requesting the RMA.
3. A copy of the Return Material Authorization must accompany the return shipment.
4. Freight is at the sender's expense. All parts must be returned freight prepaid to Multiquip's designated receiving point.

5. Parts must be in new and resalable condition, in the original Multiquip package (if any), and with Multiquip part numbers clearly marked.
6. The following items are not returnable:
  - a. Obsolete parts. (If an item is in the price book and shows as being replaced by another item, it is obsolete.)
  - b. Any parts with a limited shelf life (such as gaskets, seals, "O" rings, and other rubber parts) that were purchased more than six months prior to the return date.
  - c. Any line item with an extended dealer net price of less than \$5.00.
  - d. Special order items.
  - e. Electrical components.
  - f. Paint, chemicals, and lubricants.
  - g. Decals and paper products.
  - h. Items purchased in kits.
7. The sender will be notified of any material received that is not acceptable.
8. Such material will be held for five working days from notification, pending instructions. If a reply is not received within five days, the material will be returned to the sender at his expense.
9. Credit on returned parts will be issued at dealer net price at time of the original purchase, less a 15% restocking charge.
10. In cases where an item is accepted, for which the original purchase document can not be determined, the price will be based on the list price that was effective twelve months prior to the RMA date.
11. Credit issued will be applied to future purchases only.

## PRICING AND REBATES

Prices are subject to change without prior notice. Price changes are effective on a specific date and all orders received on or after that date will be billed at the revised price. Rebates for price declines and added charges for price increases will not be made for stock on hand at the time of any price change.

Multiquip reserves the right to quote and sell direct to Government agencies, and to Original Equipment Manufacturer accounts who use our products as integral parts of their own products.

## SPECIAL EXPEDITING SERVICE

A \$35.00 surcharge will be added to the invoice for special handling including bus shipments, insured parcel post or in cases where Multiquip must personally deliver the parts to the carrier.

## LIMITATIONS OF SELLER'S LIABILITY

Multiquip shall not be liable hereunder for damages in excess of the purchase price of the item with respect to which damages are claimed, and in no event shall Multiquip be liable for loss of profit or good will or for any other special, consequential or incidental damages.

## LIMITATION OF WARRANTIES

No warranties, express or implied, are made in connection with the sale of parts or trade accessories nor as to any engine not manufactured by Multiquip. Such warranties made in connection with the sale of new, complete units are made exclusively by a statement of warranty packaged with such units, and Multiquip neither assumes nor authorizes any person to assume for it any other obligation or liability whatever in connection with the sale of its products. Apart from such written statement of warranty, there are no warranties, express, implied or statutory, which extend beyond the description of the products on the face hereof.

Effective: February 22, 2006



# OPERATION AND PARTS MANUAL

## HERE'S HOW TO GET HELP

PLEASE HAVE THE MODEL AND SERIAL  
NUMBER ON-HAND WHEN CALLING

### UNITED STATES

#### ***Multiquip Corporate Office***

18910 Wilmington Ave.  
Carson, CA 90746  
Contact: mq@multiquip.com

Tel. (800) 421-1244  
Fax (310) 537-3927

#### ***Service Department***

800-421-1244  
310-537-3700

#### ***Technical Assistance***

800-478-1244

Fax: 310-943-2238

#### ***MQ Parts Department***

800-427-1244  
310-537-3700

Fax: 800-672-7877

#### ***Warranty Department***

800-421-1244  
310-537-3700

Fax: 310-943-2249

### CANADA

#### ***Multiquip***

4110 Industriel Boul.  
Laval, Quebec, Canada H7L 6V3  
Contact: infocanda@multiquip.com

Tel: (450) 625-2244  
Tel: (877) 963-4411  
Fax: (450) 625-8664

### UNITED KINGDOM

#### ***Multiquip (UK) Limited Head Office***

Unit 2, Northpoint Industrial Estate,  
Globe Lane,  
Dukinfield, Cheshire SK16 4UJ  
Contact: sales@multiquip.co.uk

Tel: 0161 339 2223  
Fax: 0161 339 3226

© COPYRIGHT 2016, MULTIQUIP INC.

Multiquip Inc, the MQ logo and the MQ Power logo are registered trademarks of Multiquip Inc. and may not be used, reproduced, or altered without written permission. All other trademarks are the property of their respective owners and used with permission.

This manual MUST accompany the equipment at all times. This manual is considered a permanent part of the equipment and should remain with the unit if resold.

The information and specifications included in this publication were in effect at the time of approval for printing. Illustrations, descriptions, references and technical data contained in this manual are for guidance only and may not be considered as binding. Multiquip Inc. reserves the right to discontinue or change specifications, design or the information published in this publication at any time without notice and without incurring any obligations.

Your Local Dealer is:

Manufactured for  
Multiquip Inc.  
by  
DENYO CO., LTD, JAPAN

